Table of Contents

Power Management

Subject	Page
Introduction	5
Model Overview	7
Power Management	8
Adaptation of the Alternator Charging Voltage	9
Idle Speed Increase	9
Reducing Peak Loads	9
Electrical Load/consumer Deactivation	10
Closed-circuit Current Diagnosis	10
Battery Charge Management	10
Battery - state of Health	11
Data Transfer to the IBS	11
Transport Mode	11
Electrical System and Battery Diagnosis	13
Stationary Cycle	13
Closed-circuit Current	15
Closed-circuit Current Measurement	16
Closed Circuit Current Measurement with the IMIB	17
Energy Management Systems	21
Energy Management with Power Module	22
Optimum Charging	23
Detection of state of charge of battery	23
Temperature-Dependent Battery Charging Voltage	24
Idle Speed Increase	24
Peak Load Reduction	24
Load/consumer Deactivation	25
Load/consumer Deactivation in Event of Undervoltage	25
Deactivation of stationary loads/consumers	25
Closed-circuit Current Monitoring	26
Distribution Mode	26
Electronic Fuse	27
Rear Window Heater	27
Interior Lighting	27
Trunk Lid and Fuel Tank Flap Control	28
Anti-theft Alarm System	28
Information Memory	28

Subject	Page
Emergency Mode Functions	28
Battery temperature sensor	28
Battery switch	28
Terminal 15_w	28
Bus Communication	28
Energy Management with Micro-Power Module	29
Intelligent Battery Sensor	29
Functional Principle of IBS	30
Charge Management by the IBS	31
Terminal 15 Wake-up	32
Terminal 30g Relay (E6x) - Time Dependent	32
Switch-on and switch-off conditions of terminal 30 g relay ...	33
Service Mode	34
Micro-power Module with Bistable Relay	35
Integration in the K-CAN	35
Normal mode	36
Sleep mode	37
Energy Management with Junction Box	38
Basic Power Management	38
BPM charging voltage specification	39
APM (Advanced Power Management)	39
APM charging voltage specification	40
Effect of Outside Temperature	41
Battery Regeneration	41
Emergency Operation	41
Electric Load Reduction	42
Class A Electrical Devices	42
Class B Electrical Devices	43
Electric load reduction	44
Energy Flow	44
Information Flow	45
Vehicle in Stationary Mode (terminal R and terminal 30)	46
Electric Loads in Stationary Mode	46
Stationary Load Log-off	46
Terminal 30g and Terminal 30g_f	46
General Measures (E70)	49
Continuous Positive	49
System Components	50
Components	50
Intelligent Battery Sensor (IBS)	50
Wake-up Function	52
Commissioning	53
Junction Box Module	54

Subject	Page
Engine Management (Power Management)54
Terminal Control55
Terminal 30g and terminal 30g_f56
Time-dependent Shutdown (terminal 30g)56
Fault-dependent Shutdown (terminal 30g_f)57
New Terminal Designation57
Terminal 15N59
Terminal 30B59
Terminal 30F60
F0x Terminal Control61
Terminal Relays62
General Measures (F0x)63
Power Supply Schematics64

Power Management

Model: All

Production: All

OBJECTIVES

After completion of this module you will be able to:

- Understand the purpose of the Energy Management System.
- Locate and Identify Energy Management System Components.
- Describe the different Energy Management systems currently used in BMW vehicles.
- Perform closed-circuit current diagnosis.

Introduction

The power supply of most current BMW vehicles is a combination of hardware and software that ensures the necessary power for all the vehicle systems.

Essentially it can be divided into two major functions:

- Energy management
- Power management

The energy management system ensures that sufficient starter motor current is always available and monitors the vehicle even when the engine is off. Energy management includes all the components in the vehicle that generate, store and consume energy. The data for the energy management is distributed across a number of control modules.

Power management is a subsystem of the energy management. The power management is run from the engine control module Digital Engine Electronics or Digital Diesel Electronics (DME or DDE). While the vehicle is being driven, the power management regulates the power output of the alternator as well as the battery charging.

For more information regarding Power Supply components refer to the Power Supply section of this training material.



Index	Explanation	Index	Explanation
1	Engine	5	Junction box
2	Alternator	6	Electrical load/consumers
3	Intelligent battery terminal	7	Engine management - power management
4	Battery		

A vehicle's electrical system basically consists of an energy storage device (battery), an energy generator (alternator) and a large number of electrical loads (electrical/electronic devices). Electrical energy is taken from the battery in order to start the engine via the starter (electric load). Once the engine is running, the alternator supplies current which, in the ideal case, is sufficient to supply all electric loads and charge the battery. If the current requirement of the connected electrical loads is higher than the current supplied by the alternator, the system voltage will drop to the level of the battery voltage and the battery will be discharged.



The task of the vehicle electrical system is to provide electrical energy for the vehicle and all its functions. Priority is given to maintaining the starting capability of the vehicle. The purpose of the energy management system is to ensure and balance the energy in the vehicle under all operating conditions.

The main component of every energy management system is the power management software in the engine control unit (DME/DDE). The task of the power management software is to control the flow of energy in the vehicle.

The alternator is designed to supply current to all electrical loads and charge the battery. If the alternator is not able to supply sufficient current to the electrical loads the additional current requirement is taken from the battery.



Model Overview

The energy management systems described here are installed in the models listed below.

Models	Charge voltage increase	Idle speed increase	IBS	Power module	Micro-power module	Junction box
E52	Yes	Yes				
E53	Yes	Yes				
E60/E61	Yes	Yes	Yes		Yes	
E63/E64	Yes	Yes	Yes		Yes	
E65/E66	Yes	Yes		Yes		
E82/E88	Yes	Yes	Yes			Yes
E83	Yes	Yes				
E85	Yes	Yes				
E86	Yes	Yes				
E89	Yes	Yes	Yes			Yes
E90 BPM	Yes	Yes				Yes
E90 APM	Yes	Yes	Yes			Yes
E70/E71	Yes	Yes	Yes			Yes
F01/F02	Yes	Yes	Yes			Yes
F07	Yes	Yes	Yes			Yes
F10	Yes	Yes	Yes			Yes

Power Management

The main component of every energy management system is the power management software in the DME/DDE. The power management is a subsystem of the energy management system that controls the flow of energy in the vehicle.

The power management system regulates the power consumption of some of the most important electrical devices and the power output of the alternator while the vehicle is being driven.

The power management functions are carried out by the engine management control module (DME). In most current BMW vehicles the IBS is partially responsible for power management when the vehicle is at rest.

The tasks of the power management system include:

- Adaptation of the alternator charging voltage.
- Idle speed boost for increasing the power output of the alternator.
- Reduction of peak loads in the event of a shortfall in coverage provided by the vehicle electrical system.
- Deactivation by means of bus messages of electric loads such telephone, on reaching the start capability limit of the vehicle.
- Closed-circuit current diagnosis.

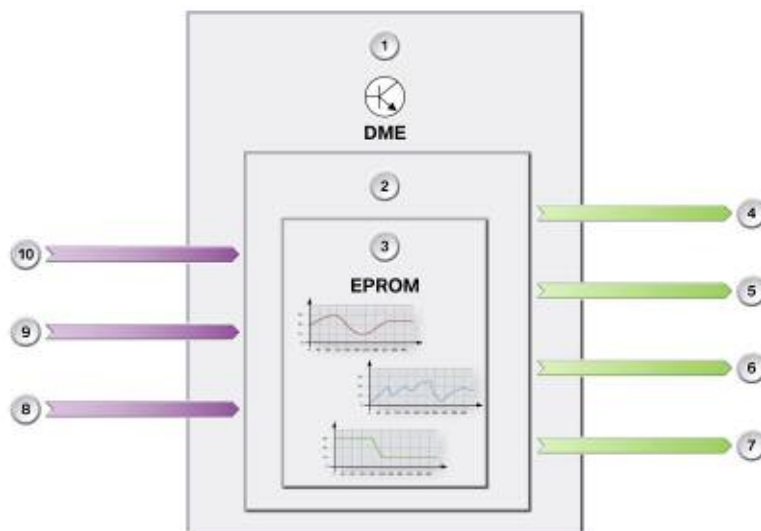

Index	Explanation	Index	Explanation
1	DME (Digital Motor Electronics)	6	Stationary load/consumer deactivation
2	Power management	7	Peak load reduction
3	EPROM with stored curves	8	Temperature input T
4	Idle-speed control	9	Current input I ±
5	Specified charging voltage for the alternator	10	Battery voltage U

Adaptation of the Alternator Charging Voltage

In unfavorable road situations, such as e.g. urban traffic or traffic jams, the variable battery charging voltage ensures a better battery charge balance.

The power management controls the specified voltage for the charging voltage of the alternator via the BSD line.

The specified voltage is dependent on:

- The battery temperature
- The current consumption of the vehicle

The battery charging voltage is controlled as a function of temperature. In this way, the battery uses less water during the charging procedure and does not degas as quickly at higher outside temperatures.

Idle Speed Increase

If the specified voltage on its own is no longer sufficient and the battery is showing a deficit, the DME increases the idle speed up to 200 rpm (F0x).

Criteria for increasing idle speed are:

- Alternator fully utilized
- State of battery charge is low

Reducing Peak Loads

The peak load of the vehicle electrical system is reduced when there is still a shortfall in battery coverage despite boosting idle speed.

Peak load reduction is realized by:

- Reducing power output, e.g. by correspondingly controlling the clock cycles of the rear window defogger.
- If reducing the power output is not sufficient, individual electric loads can be switched off in extreme situations.

Electrical Load/consumer Deactivation

The loads/consumers can be categorized as follows:

- Comfort loads/consumers, e.g. heated window, seat heating, steering wheel heating.
 - These loads/consumers switch off automatically after engine "OFF" and can be activated again after the vehicle has been restarted.
- Stationary loads/consumers required by law, e.g. side lights, hazard warning lights, must be operational after engine "OFF" for a specific length of time.
 - Legally required stationary loads/ consumers are not switched off even on reaching the start capability limit of the battery.
- Other stationary loads/consumers, e.g. independent heating, independent ventilation, central information display, telephone, telematic services.
 - Other stationary loads/consumers can be switched on after engine "OFF." The comfort electric loads/consumers switch off automatically on reaching the start capability limit of the battery. Switch-off is requested by the DME in the form of a CAN message.
- System-related afterrunning loads/ consumers, e.g. electric radiator fan.
 - System-related afterrunning loads/ consumers can maintain operation for a defined period of time.

Closed-circuit Current Diagnosis

A fault code is stored in the DME/DDE when the battery current exceeds a defined value during the vehicle rest phase.

Battery Charge Management

There are two "counters" in the power management module. One counter is responsible for the battery charge and the other for the battery discharge level. The state of charge of the battery SoC is formed by the difference between the charge acceptance and draw levels. The power management module receives the corresponding data from the IBS via the BSD line.

The power management module calculates the current SoC value on restarting the vehicle.

Battery - state of Health

When the vehicle is started, the battery terminal voltage and the starting current of the starter are measured by the IBS.

The starting current and voltage dip determined during the start phase are transferred via the BSD line to the DME/DDE. From these data, the power management module calculates the state of health (SoH) of the battery.

Data Transfer to the IBS

The following data are transferred via the BSD line (or LIN Bus depending on model) to the IBS before the DME goes into sleep mode:

- State of charge of the battery (SoC)
- Outside temperature
- Available discharge level
- Terminal 15 wake-up enable
- Terminal 15 wake-up disable
- DME close



Transport Mode

Indication of Battery Condition

The batteries in vehicles coming off the production line are adequately charged so that SOC > 80% (SOC = "State of charge"). However, since several days or weeks can pass between the time the vehicle comes off the production line and when it is delivered to the customer, the battery will have discharged to a greater or lesser degree. Therefore, every battery must be charged according to the recharging calendar.

The F01/F02 is the first model on which it is possible to display the charge level of the battery when the new car is being transported. When production or transport mode is activated, a Check Control message is generated that provides a quick indication of the battery condition.

Note: If the SOC has dropped to less than 35%, the indication continues to be displayed on the instrument cluster until the battery is replaced and a change of battery is registered.

Battery condition	Display on instrument cluster	Audible signal	Action
Battery condition OK SOC 60% to 100%		No sound	No action necessary.
Battery is discharged. SOC 35% to 60%		No sound	Charge battery.
Battery charge level is very low. SOC less than 35%		Double gong	Replace battery.

Note: When transport mode is reset, there is no indication on the instrument cluster of the battery charge level.

Note: If the vehicle is delivered with the red Check Control message “Battery charge level very low” active, it is essential that the low battery charge is recorded as transport damage on the delivery note.

In such cases, the test module “Energy diagnosis” must be carried out to establish the cause. Replace the battery before handing over the vehicle to the customer and register the change of battery using the service function.



If a vehicle is delivered with the yellow Check Control message “Charge battery”, this should also be recorded on the delivery note. The battery must then be charged once and an energy diagnosis carried out.

Electrical System and Battery Diagnosis

Over the past few years, the energy management of all BMW models has been continuously improved and standardized across the various model series. In terms of energy diagnosis, this also means standardization of testing schedules and displays in the BMW diagnostic system.

The aim of the diagnostic procedures is to show the causes of a discharged battery as unambiguously as possible. In view of the complexity, especially in the area of energy management, the specific cause of a fault can be shown only partially depending on its nature. The acquired energy diagnosis data are shown if the fault cannot be clearly assigned based on the acquired data.

Power management is retained in full while the expanded diagnostic options are now resident in the history memory.

In F0x vehicles the ZGM monitors the vehicle status, registers inhibited sleep mode or unauthorized wake-up after Terminal 30B is switched off and requests a reset or shut-down of Terminal 30F by a bus message to the JBE.

The originator and reason for wake-up (unauthorized wake-up) are stored as additional information in the ZGM fault memory. The driving profile for the last 5 weeks is stored in the JBE energy history memory. The energy history memory is referred to for energy diagnosis purposes.

Stationary Cycle

After the engine has been turned off, the battery undertakes the task of supplying electrical loads with current. The number of electrical loads that can be activated with the ignition turned off is limited in order not to excessively discharge the battery. Only a few functions are available such as the radio, exterior/interior lights, hazard warning lights or renewed engine start. Functions such as the seat heating, rear window defogger, air conditioning etc. cannot be activated.

Several control units are disconnected from the power supply after a specific period of time so that the battery is not permanently subjected to load. This is known as "Sleep Mode" or the rest state of the control units. For example, the radio or the interior lighting are switched off automatically after a certain period of time. Exceptions include control units that are responsible for the functions required by law, e.g. exterior lighting.

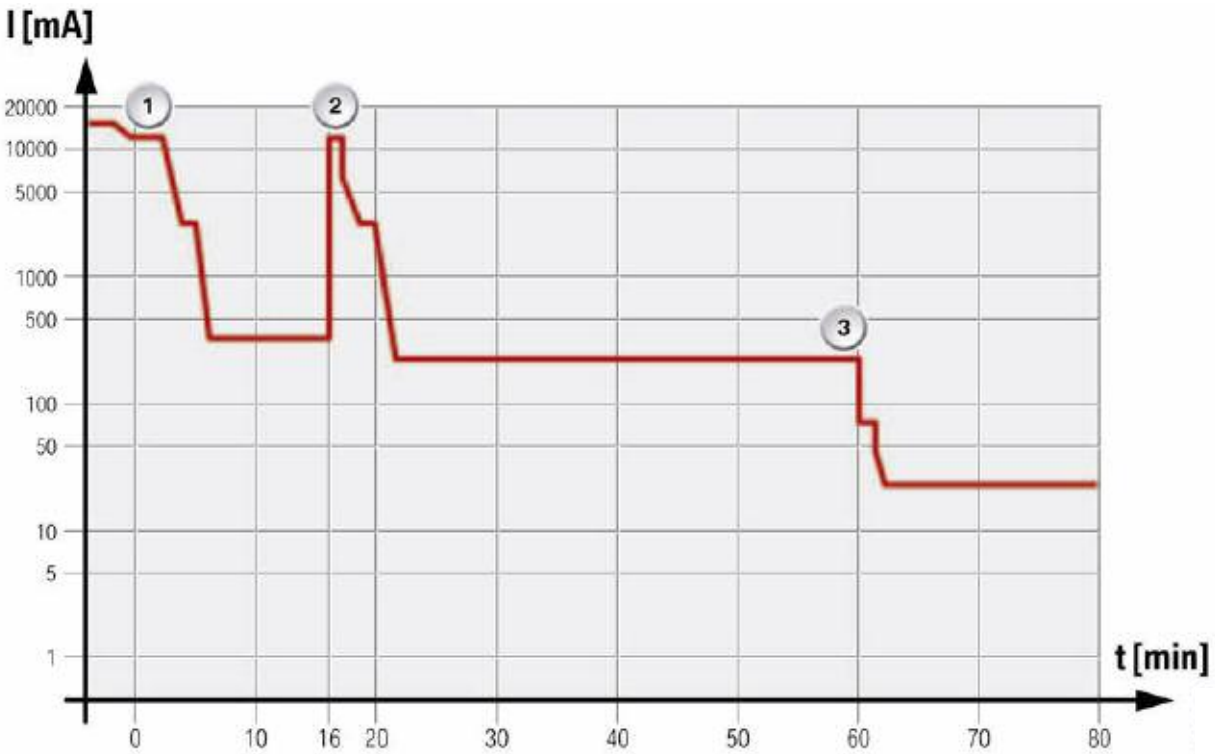

Index	Explanation	Index	Explanation
1	Terminal R "OFF"	3	telephone shutdown
2	Electric load deactivation		Electronic ride-height control

In order to protect the battery, ideally the battery should be disconnected from the electrical system after shutting down and locking the vehicle. This, however, is not possible as the antitheft alarm system, for instance, must remain in operation or the control unit for unlocking the vehicle (CAS) must receive current at all times. Consequently, this means that electrical energy is constantly taken from the battery while the vehicle is stationary and a small current, the so-called closed-circuit current, flows. The number of control units that are supplied with current via terminal 30 (continuous positive) is kept to a minimum so that a maximum closed-circuit current of 80 mA is not exceeded in BMW vehicles. This measure ensures the battery does not suffer exhaustive discharge even over longer periods of time.

A fault code is stored in the DME/DDE if the battery current exceeds a value of 80 mA during the vehicle rest phase. The energy management initiates automatic shutdown if some control units cannot assume sleep mode after a certain period of time.

Closed-circuit Current

Although for most models a closed circuit current reading **below 50mA** is preferred, a Check Control message is generated (raised battery discharge rate when parked) if a closed-circuit current level of **>80 mA** is detected.

Note: The closed-circuit current should always be measured if increased current consumption is suspected. Even power consumption levels only slightly above normal can cause relatively rapid battery discharge.

The graph below shows the typical closed-circuit current progression on the F01/F02 associated with the various electrical system statuses. The actual current values change depending on the vehicle equipment configuration.

The terminal “load shut-down” (e.g. reading or 60 minutes with light and vanity mirror light) is switched off corresponding to the terminal status.

Load shut-down switches off immediately when the vehicle is secured. In all other terminal statuses, the load shut-down terminal is switched off after an overrun period of 8 minutes. It is activated by the footwell module.

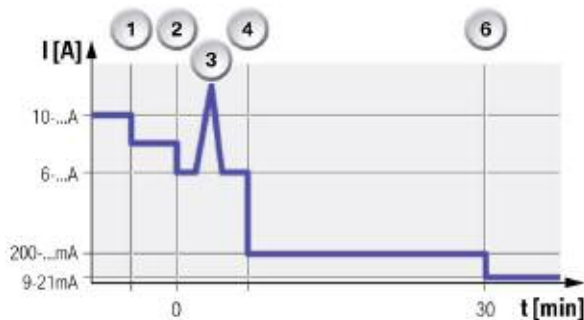

Typical closed-circuit current progression for double-locked vehicle on F01/F02

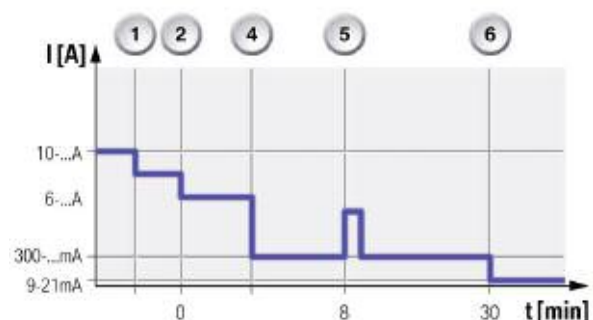

Typical closed-circuit current progression for unlocked vehicle on F01/ F02

Index	Explanation
1	Terminal 15N off
2	Terminal R off
3	Vehicle is secured (locked)
4	Start of bus rest phase
5	Electrical load shutdown after 8 minutes
6	KL30 B OFF (30 minutes w/o phone or 60 min with phone)



The Maximum current draw recorded in the above graphs is 9-21mA after 30 min which is normal for the F01 with a TCU. For further information, please reference SI B61 08 00 Closed Circuit Measurement.

Closed-circuit Current Measurement

Increased closed-circuit currents may occur permanently or intermittently and cause the battery to discharge prematurely. The increase in closed-circuit current may be caused by a faulty control unit, or by the installation of a non-approved accessory.

In a situation where a vehicle has broken down due to a discharged battery, for diagnostic purposes it is important not to disconnect the battery. This is because a control unit will be reset if the battery is disconnected. Following a reset, the faulty control unit may start functioning correctly again, making accurate diagnosis impossible.

To correctly measure closed-circuit current, the 50-amp clip-on probe (previously used with the MIB) can now be used in conjunction with the IMIB (Integrated Measurement Interface Box) to properly diagnosis closed-circuit current problems over an extended period of time. Connect the 50-amp clip-on probe directly to the IMIB Measurement input 3 (green socket). Refer to SI B04 35 09 for information about the IMIB.

Note: Refer to the Battery Service Information section in this training material for more information on Closed Circuit Current measurement and to SI B61 08 00.

Vehicle	Closed circuit current measurement
E36, Z3	30 milliamps after 16 minutes
E46	40 milliamps after 16 minutes
E60, E61, E63, E64	40 milliamps after 60-70 minutes
E65, E66	40 milliamps after 60-70 minutes
E53	40 milliamps after 16 minutes
E70, E71, E72	40 milliamps after 60-70 minutes with TCU (30 minutes without TCU)
E83	40 milliamps after 16 minutes
E82, E88	40 milliamps after 60-70 minutes with TCU (30 minutes without TCU)
E90, E91, E92, E93	40 milliamps after 60-70 minutes with TCU (30 minutes without TCU)
E85	40 milliamps after 16 minutes
E89	40 milliamps after 60-70 minutes with TCU (30 minutes without TCU)
E52	50 milliamps after 16 minutes
F01, F02, F07, F10	7-21 milliamps after 30 minutes

Note: When performing a Closed Circuit Current measurement always consult the individual vehicle specifications all vehicle models may be different. (See closed circuit current measurement chart)

■ Closed Circuit Current Measurement with the IMIB

This technique with an IMIB is particularly suitable for extended measurements, and provides a graphical readout of recorded measurements over time. It is recommended for situations where the use of a multimeter provided insufficient information for problem diagnosis.

1. The IMIB can be accessed from any ISID within the workshop.
2. Select "Activities".
3. Select "Measuring devices".
4. Select from the "Level 1" column, "Measuring devices", and then "OK".
5. From the "Connection manager" screen, select the free IMIB and "Set up connection".
6. The "Measures devices" screen opens on the "Multimeter" tab.
7. Select the "Oscilloscope" tab.
8. Highlight the "CH1" tab to activate channel 1.
9. Under channel 1, "Source", scroll with the arrows to select "Clip-on probe 50A".
10. Make sure that clip-on probe is not connected to the battery cable, and acknowledge the pop-up message with "OK".
11. Change the "A/Div" setting to "1A".
12. Under the "Time" selection box, change the "Time/Div" setting based on the number of measurements needed (5 ms to 200 s). The longer times should be selected when performing the measurement over an extended period.
13. Select "CH 1" under "Cursor" to monitor the actual readings.
14. Select "Record" if performing long term measurements.
15. After performing the measurement, select "Record" again; the display will change to "Compress" and display the recorded data on the 1 screen.



For further information regarding Closed-circuit Current Measurement refer to SI B61 08 00 available in ISTA.

Closed circuit current monitoring using the IMIB and the “Clip-on probe 50A or 100A”

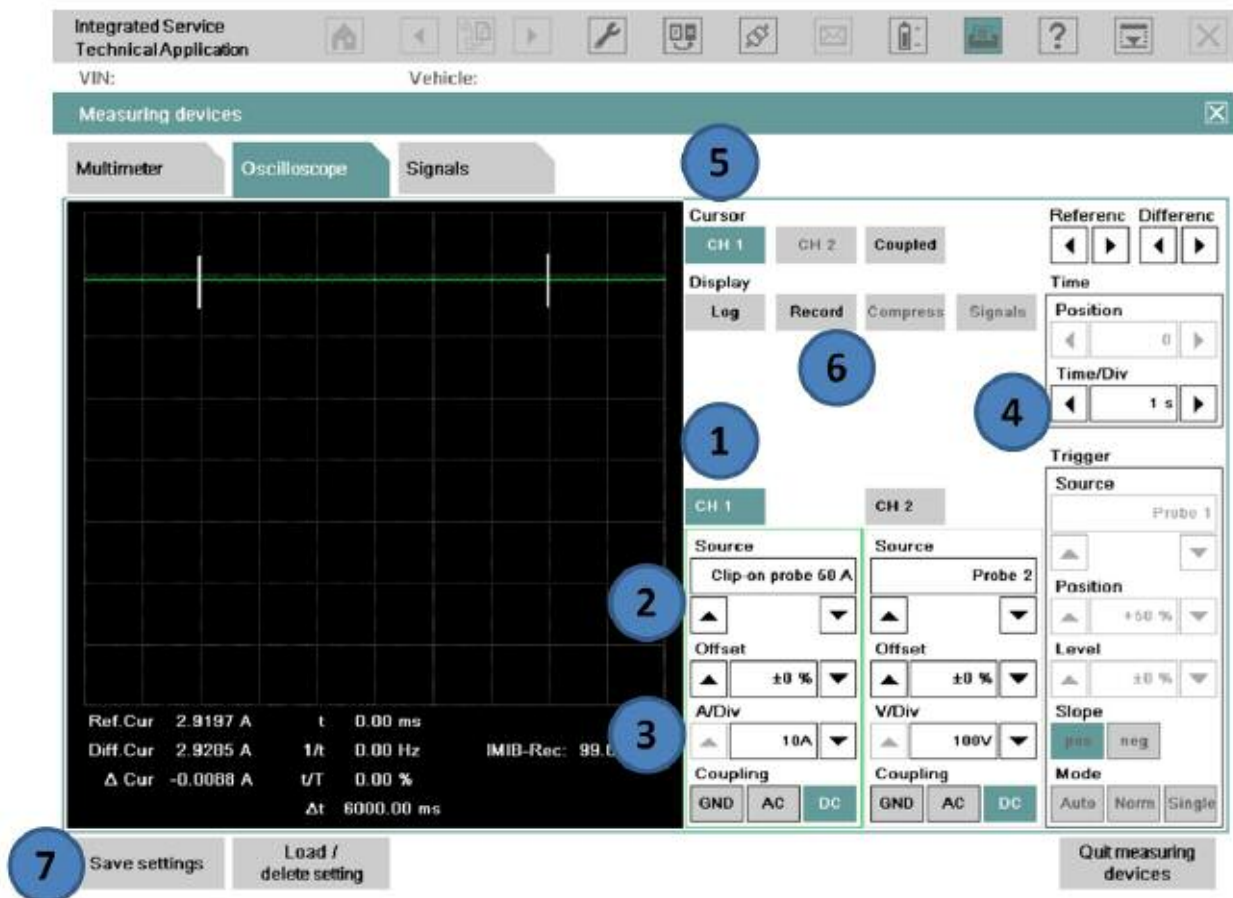

- (1) Select channel 1 or 2.
- (2) Change the “Source” to “Clip-on probe 50A or 100A” (confirm calibration prompt).
- (3) Set “A/DIV” to “10A”.
- (4) Change the “Time/DIV” in the “Time” box to “1 s” to start (the value can be changed if longer recording time is needed).
- (5) Select the “Cursor” for the channel selected, 1 or 2.
- (6) Once the measurement is started, press the “Record” button to start monitoring.
- (7) Select “Save settings” to save the configuration setup (can be loaded back up at a later time).

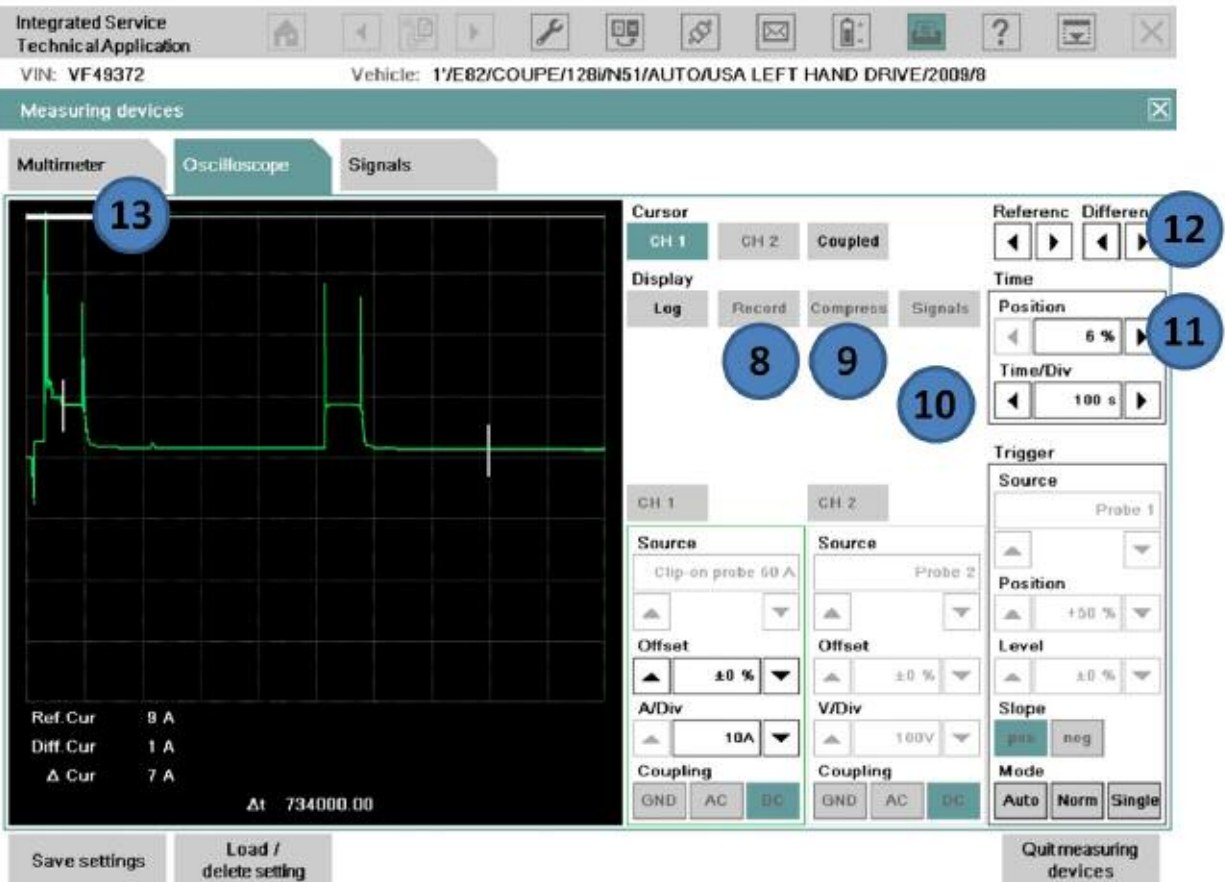

- (8) Select the “Record” button to stop recording.
- (9) Select the “Compress” button to start analyzing the recorded signal.
- (10) Change the “Time/DIV” in the “Time” box to the value which makes the signal easier to view glitches.
- (11) Change the “Position” in the “Time” box to scroll through the signal.
- (12) The white bar along the top of the display indicates the part of the entire signal being viewed.
- (13) The cursor(s) may be moved to display the value of different parts of the display.

NOTES

PAGE

Energy Management Systems

Depending on the vehicle and the requirement, the functions available in the power management module are modified with various further components. This results in different energy management solutions for BMW vehicles.

The following table provides an overview of the different energy management systems and their functions.

Function	BPM	PM	MPM	JB
Charging voltage increase	X	X	X	X
Idle speed increase	X	X	X	X
Load/consumer deactivation, load		X	X	X
Load/consumer deactivation, fault			X	X
Peak load reduction		X	X	X
Closed-circuit current monitoring, partial		X		
Closed-circuit current monitoring with IBS			X	X
Battery diagnosis		X	X	X

Legend:

BPM= Basic Energy Management (E53)

PM = Power Module (E65-E66)

MPM = Micro-power Module (E60-E64)

JB = Junction Box (E82, E88, E89, E9x, E7x, F0x)

Note: Energy management for the E83, E85 and E86 is built into the DME and is taken from the E46.

The following chapter provides an overview of the different energy management systems and their functions.

The following systems are discussed:

- Energy management with power module
- Energy management with micro-power module
- Energy management with junction box

Energy Management with Power Module

The functions listed below are integrated in the power module and form part of energy management for the BMW E65/E66.

Power module in luggage compartment, rear right



Index	Explanation	Index	Explanation
1	Battery switch	4	Power module
2	Battery positive cable	5	Terminal 30B
3	Terminal 30U		

Features:

- Optimum battery charging
- Load-side peak reduction
- Deactivation of stationary loads/consumers
- Load/consumer deactivation
- Closed-circuit current monitoring
- Distribution mode
- Automatic electrical system disconnection
- Electronic fuse

- Central battery voltage specification
- Heated rear window
- Interior lights
- Trunk lid and fuel tank flap control
- Information memory
- Limp home properties
- Check Control message
- Diagnosis

Optimum Charging

The battery voltage can vary between 14 V and 15.5 V. The optimum charging voltage is set by the power module as a function of the state of charge of the battery, the battery temperature and the lamp resistance. The maximum charging voltage is 16 V.

■ Detection of state of charge of battery

The power module detects the state of charge of the battery at all times by calculating the battery current while the vehicle is moving and by measuring the discharge current. When the vehicle is stationary, the state of charge is recalculated by means of a closed-circuit voltage measurement at the battery and adopted.

Data flow, power module/alternator

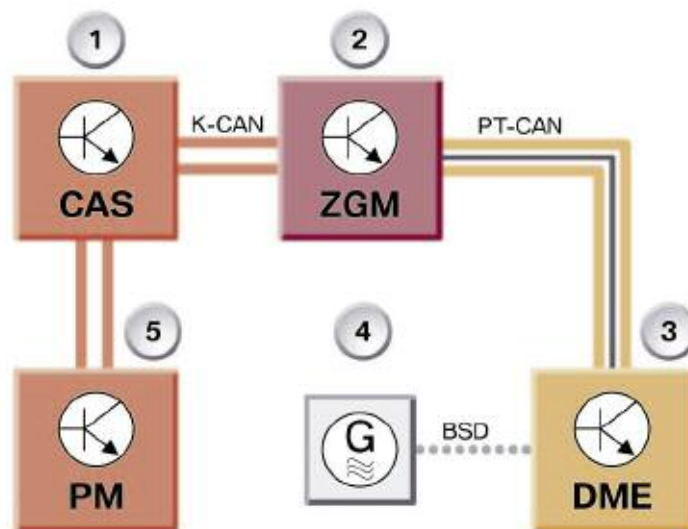

Index	Explanation	Index	Explanation
1	CAS (Car Access System)	4	Alternator
2	ZGM (central gateway module)	5	Power module
3	DME (Digital MotorElectronics)	BSD	Bit-serial data interface

■ **Temperature-Dependent Battery Charging Voltage**

By using a charging characteristic map stored in the PM, the charge voltage of the generator is adjusted according to the battery temperature. The previous diagram shows the communication path necessary for the Power Module to inform the generator to increase or decrease charge voltage output. The alternator charging voltage is set as a function of the battery temperature using the charging curve stored in the power module.

The power module detects the temperature of the battery and sends the message "Charging voltage increase" to the K-CAN PERIPHERALS. The CAS forwards the message to the K-CAN SYSTEM.

The central gateway module receives the message and forwards it to the PT-CAN. The Digital Motor Electronics receives the request to increase the charging voltage via the PTCAN.

The alternator receives the request to increase the charging voltage via the BSD line. The electronic evaluation unit in the alternator sets the requested charging voltage.

■ **Idle Speed Increase**

As little energy as possible is drawn from the battery in the interests of improving the charge balance. The idle speed is increased early in order to prevent an increased draw of energy. This ensures that the battery has a higher state of charge.

If this drops below the calculated start capability of the battery, the idle speed is increased to 750 rpm.

■ **Peak Load Reduction**

Load-side peak reduction If while the engine is running a battery discharge (in spite of increased idle speed) is detected, loads/consumers are reduced or deactivated in stages in accordance with a priority table.

These loads/consumers are:

- Heated rear window
- Seat heating
- Heater fan (without defrost function)
- Steering wheel heating
- Mirror heating
- Wiper console heating

Load/consumer Deactivation

In order that the battery is not discharged in the event of a permanent activation of loads/consumers, a central load/consumer deactivation is performed 16 minutes after terminal R off.

These loads/consumers are:

- IB (Interior lights)
- VA_K (Load/consumer deactivation, body area)
- VA_D (Load/consumer deactivation, roof area)

Load/consumer Deactivation in Event of Undervoltage

In the event of an undervoltage due to high loads, the power module transmits a message to increase idle speed and for load/consumer deactivation after the voltage drops below 10.5 V (for 5 seconds). Load/consumer deactivation is conducted in accordance with the priorities stored in the power module.

The power outputs of the power module are deactivated at the same time.

These loads/consumers are:

- IB (Interior lights)
- VA_K (Load/consumer deactivation, body area)
- VA_D (Load/consumer deactivation, roof area)

Deactivation of stationary loads/consumers

In order to safeguard the start capability of the vehicle, the state of battery charge is also monitored when the vehicle is stopped.

A minimum state of charge is determined in order to guarantee start capability.

This is dependent on:

- The measured temperature of the last few days
- The engine type
- The capacity of the installed battery

If the state of charge approaches this limit value because a stationary load/consumer is active, the power module prompts this load/consumer to switch itself off.

The following are stationary loads/consumers:

- CD (Color Display)
- DWA (Anti-theft alarm system)
- LSZ (Light switch center)
- EGS (Electronic transmission control)
- IHKA (Integrated automatic heating/air conditioning)

Closed-circuit Current Monitoring

The closed-circuit current monitoring function is activated in the power module when the battery switch is set to ON.

The power module switches to the closedcircuit current monitoring function at terminal 0 after 60 minutes. Closed-circuit current monitoring begins again if an action on the vehicle (e.g. central locking, open rear lid) occurs before a period of 60 minutes has elapsed.

After this period has elapsed the closed-circuit current must not exceed 80 mA. If however the closed-circuit current is higher than 80 mA, the message "Shutdowncounter" is sent by the power module after 5 minutes. After a further 90 seconds disconnection of the vehicle electrical system is completed for 5 seconds.

Disconnection is repeated if the closed-circuit current after reactivation is still higher than 80 mA.

If the closed-circuit current is still higher than 80 mA, permanent disconnection is performed by the electronic battery master switch.

The fault (incl. boundary conditions and the reason for the increased closed-circuit current) is set in the power module's fault memory.

When the terminal 15_w signal is detected, the electronic battery master switch is closed and a Check Control message "Increased closed-circuit current" is displayed.

Closed-circuit current monitoring is cancelled by the message Side lights ON and hazard warning lights. The loads/consumers required by law must not be deactivated.

Distribution Mode

By repositioning the battery switch, the power module switches to the Distribution mode function 30 minutes after terminal R off. Prior to disconnection the message "Shutdown" is sent by the power module. Disconnection is completed after a further 90 minutes.

After ignition lock position terminal R ON a Check Control message is sent which alerts the driver that the vehicle is in Distribution mode. The message "Battery switch OFF" appears.

The electronic battery master switch is closed when the terminal 15_w signal is detected or by repositioning the battery switch to "closedcircuit current monitoring".

Note: The vehicle can also be started and driven in Distribution mode. All the systems are operational. The Check Control message remains active. With terminal R Off, disconnection is initiated again after 30 minutes, as described above.

Electronic Fuse

The electronic battery master switch is opened when a short-circuit current in excess of 250 A is detected. Only after the terminal 15_w wake-up signal from the CAS is detected is an attempt made to close the electronic battery master switch.

The procedure is repeated until the short circuit is eliminated.

Central battery voltage specification The power module measures the battery voltage continuously. This voltage is made available to all the other electronic control units via their bus connection. This facilitates for example a continuous operation of the slide/tilt sunroof irrespectively of the battery voltage.

There are no individual measurements of the individual control units with central battery voltage specification.

Rear Window Heater

The electronic output stage of the heated rear window in the power module is activated by a K-CAN message from the IHKA control unit "Heated rear window ON" output.

Interior Lighting

The interior lights are divided into three outputs (groups).

- IB (Interior lights)
- VA_K (Load/consumer deactivation, body area)
- VA_D (Load/consumer deactivation, roof area)

The interior lights are controlled by the power module.

VA_K and VA_D are switched as a function of the corresponding ON/OFF contacts.

Trunk Lid and Fuel Tank Flap Control

The power module controls the functions of the body electronics in the area of the rear lid:

- Trunk lock actuator
- Trunk lid Soft Close Automatic
- Fuel tank flap locking

The necessary software, such as e.g. switchon times and repeat interlocks, is integrated in the power module.

Anti-theft Alarm System

The power module is used to monitor the rear lid via the SCA contact of the anti-theft alarm system.

Information Memory

Vehicle-related data are stored in the information memory. These data make it possible to indicate the status of the load and service life of the battery. The information memory can be read out by way of diagnosis.

Emergency Mode Functions

■ Battery temperature sensor

A substitute value of 20 °C is accepted in the event of an open circuit, a short circuit or an implausible value. This corresponds to a fixed charging voltage of 14.3 V at the battery.

The battery capacity can now only be calculated under limited conditions.

■ Battery switch

The system switches to closed-circuit current monitoring if the battery switch is fault-free.

■ Terminal 15_w

The following signals prevent deactivation of the power module without terminal 15_w:

- Terminal 15 (via CAS bus connection)
- Vehicle speed > 2 km/h via DSC bus connection (Dynamic Stability Control)
- System voltage > 13.2 V (PM central voltage specification)

■ Bus Communication

If bus communication is not possible, all information is "frozen."

Energy Management with Micro-Power Module

The energy management system with the micro-power module is used in the E60, E61, E63, E64. Energy management has the same basic functions as power management in the DME.

Energy management with the micro-power module differs from the E65 power module system in the following details:

- Permanent monitoring of the charge/discharge current by the intelligent battery sensor. (IBS)
- Terminal 15 wake up
- Load/consumer deactivation timecontrolled by terminal 30g relay
- Load/consumer deactivation faultcontrolled by micro-power module
- Closed-circuit current diagnosis and violation of fault storage

Intelligent Battery Sensor

The intelligent battery sensor IBS is a mechatronic component. The IBS with its own microcontroller which continually measures the following parameters:

- Battery terminal voltage
- Battery charge/discharge current
- Battery acid temperature

The IBS is located directly on the battery negative terminal and is used on all current BMW vehicle.

The intelligent battery sensor (IBS) is part of the power management system. The IBS is used to determine precisely the "state of charge" (SoC) and the "state of health" (SoH) of the battery.

Measuring ranges of IBS	
Voltage	6 V to 16.5 V
Current	-200 A to + 200 A
Closed-circuit current	0 A to 1000 A
Starting current	0 A to 1000 A
Temperature	-40 °C to 105 °C

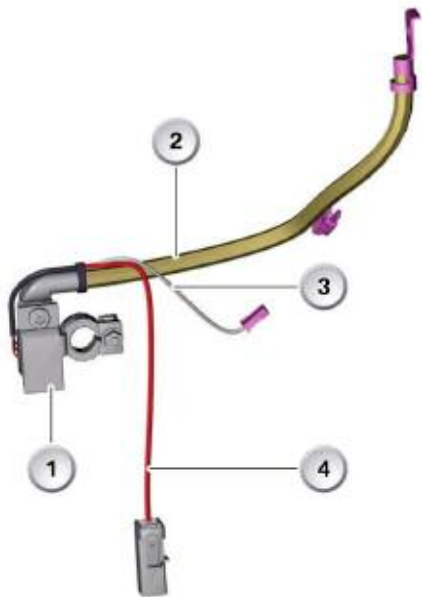

Index	Explanation
1	Intelligent battery sensor
2	Ground cable
3	Bit-serial data interface (BSD)
4	Connection B+

Functional Principle of IBS

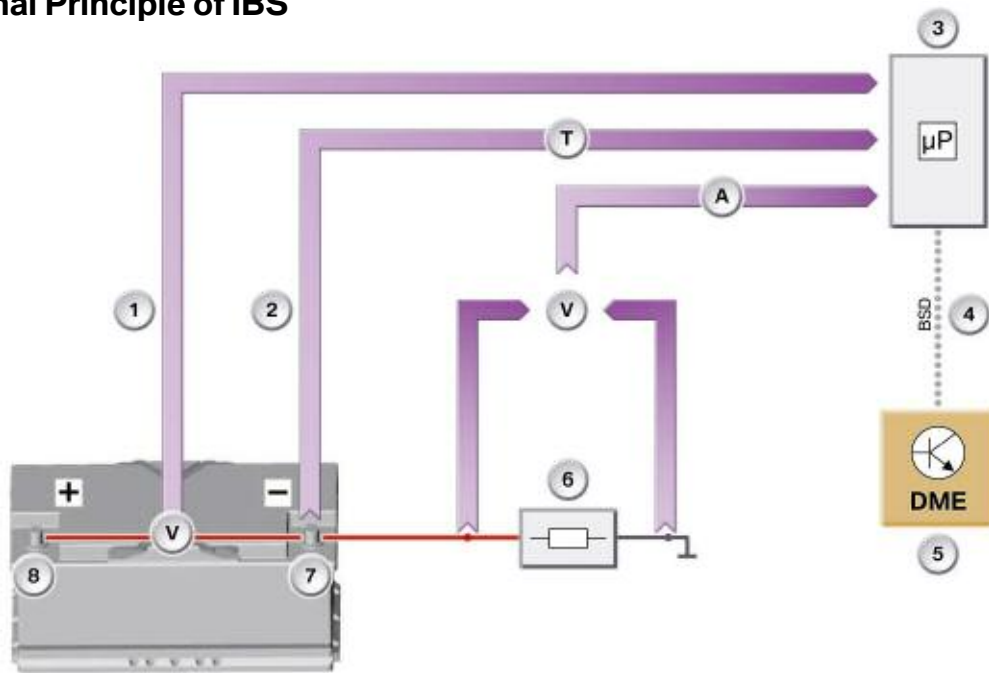

Index	Explanation	Index	Explanation
1	Battery voltage measurement	5	Digital Motor Electronics DME
2	Battery temperature measurement	6	Current measurement (voltage drop at shunt)
3	Microcontroller in IBS	7	Negative pole of battery
4	Bit-serial data interface	8	Positive pole of battery

The software in the IBS controls the process and communication with the DME (Digital Motor Electronics) control unit. The IBS sends the data via the bit-serial data interface (BSD) to the DME. The following functions are integrated in the IBS:

- Continuous measurement of the battery current, voltage and temperature under all vehicle operating conditions.
 - When the vehicle is stationary, the measured values are interrogated cyclically every 40 s to save power. The measuring period of the IBS is approx. 50 ms. The measured values are entered in the closed-circuit current histogram in the IBS.
- The state of battery charge (SoC) is partly calculated.
 - The DME/DDE reads out the closedcircuit current histogram after the vehicle is restarted. A corresponding entry is made in the fault code memory of the DME if a closedcircuit current infringement is determined.
- The IBS sends the data via a bit-serial data interface to the DME.
- Calculation of the battery indicators as the basis for the state of charge (SoC) and state of health (SoH) of the battery.
 - The battery indicators are charge and discharge current, voltage and temperature of the vehicle battery.
- Balancing of the charge and discharge currents of the battery.
- Permanent monitoring of the state of battery charge.
 - Transmission of date in the event of a deficit.
- Calculation of the current progression when starting the engine to determine the state of battery health.
- Closed-circuit current monitoring of the vehicle.

Charge Management by the IBS

The IBS continuously balances the state of battery charge even when the vehicle is stationary.

The current SoC is stored in the IBS every 2 hours. 3 locations are reserved in the memory for this purpose. The first entry is made at location 1, locations 2 and 3 are overwritten every 4 hours.

From terminal 15 "On" the DME/DDE updates the value to the current values of the battery indicators.

Terminal 15 Wake-up

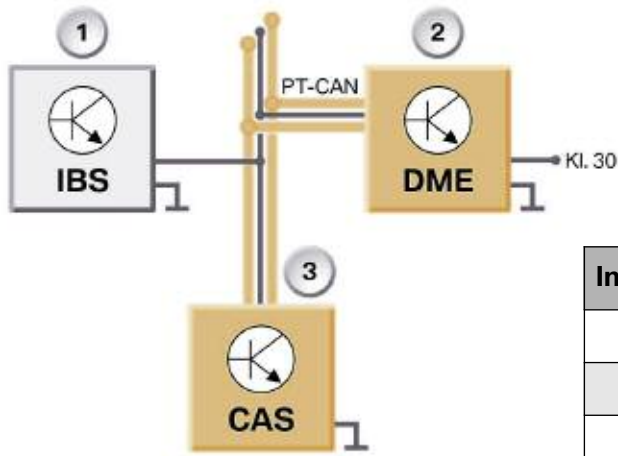

Index	Explanation
1	Intelligent battery sensor
2	Digital Motor Electronics DME
3	Car Access System CAS

Before the DME assumes sleep mode, it informs the IBS of the current SoC of the battery. The IBS sends the wake-up signal when the available SoC is used up.

The DME obtains information on the current SoC of the battery from the IBS. The IBS informs the DME when the SoC of the battery is critical.

The DME requests the stationary electrical loads/consumers to switch off. The DME no longer permits the IBS to wake the vehicle.

The vehicle subsequently reassumes sleep mode.

The wake-up function only applies when the vehicle is at rest.

Terminal 30g Relay (E6x) - Time Dependent

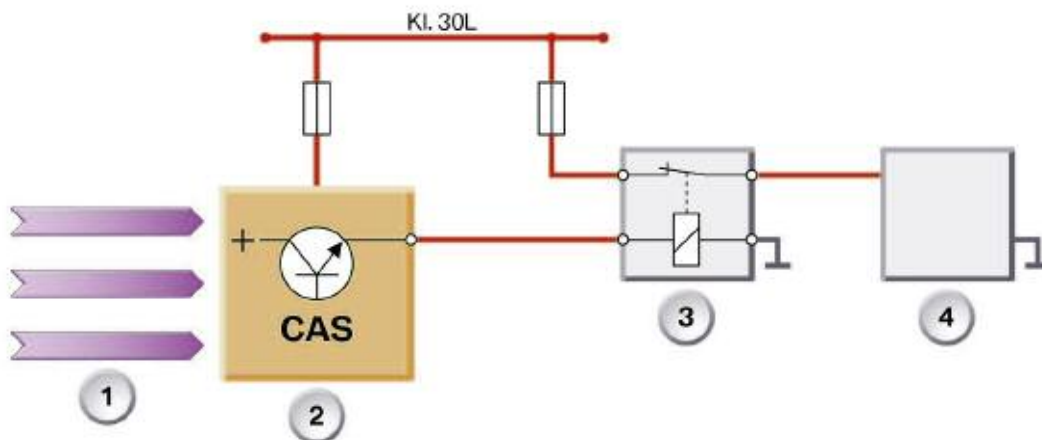

Index	Explanation	Index	Explanation
1	Input signals, terminal 30g "ON/OFF"	4	Load/consumer
2	CAS (Car Access System)	KI.30	Terminal 30, load
3	Terminal 30g relay		

In order to ensure a proper energy balance and battery start capability, specific stationary loads/consumers are deactivated by the terminal 30g relay after a prespecified period of time.

The terminal 30g relay is activated by the Car Access System CAS and effects a defined deactivation of loads/consumers.

The terminal 30g relay is installed in the power distribution box in the luggage compartment.

■ Switch-on and switch-off conditions of terminal 30 g relay

The switch-on conditions are:

- Unlock vehicle
- Terminal R "ON"
- Auto-remote closing via remote control
- Status change of door contacts or of rear lid contact
- Telephone wake-up line for telematic services
- Service application

The switch-off conditions are:

- 60 minutes after terminal R "OFF"
- Service application

Terminal 30g switch-on/switch-off conditions

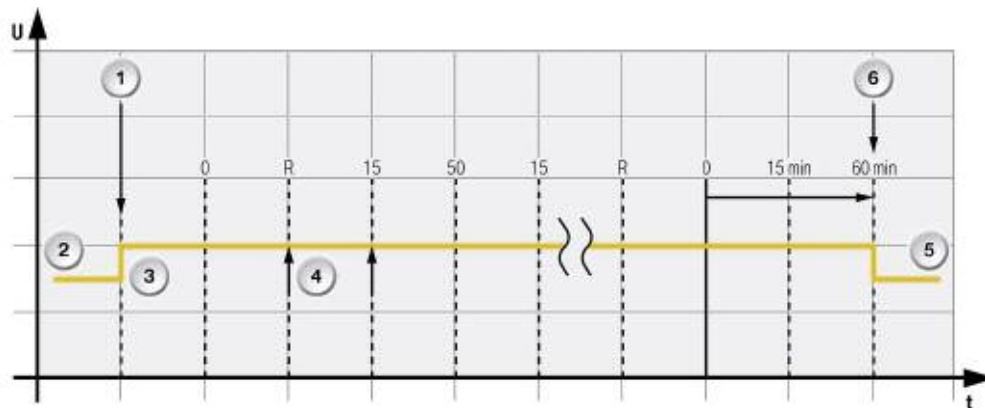

Index	Explanation	Index	Explanation
1	Terminal 30 g relay "ON"	4	Terminal R "ON"
2	OFF	5	OFF
3	ON	6	Terminal 30 g relay "OFF"

The terminal 30 g switch-off procedure disconnects various electrical loads/ consumers in a defined manner from the vehicle electrical system. This happens approx. 60 minutes after terminal R "OFF."

The deactivated loads/consumers are activated again together with terminal 30g "ON."

The following loads/consumers are deactivated:

- Center console switch center
- Rain and driving lights sensor
- Controller
- Central information display
- Slide/tilt sunroof
- Tyre pressure control
- Satellite radio
- TOP HiFi amplifier
- Telephone
- Head-up display
- Active cruise control
- Electronic transmission control
- Dynamic Stability Control
- Adaptive directional headlights

Service Mode

The BMW diagnosis system can be used to place the vehicle in sleep mode in the workshop within 5 secs. by means of the Power Down command.

This is necessary in order to carry out a quick and continuous closed-circuit current without waiting for the normal deactivation time to elapse (60 mins.).

Micro-power Module with Bistable Relay

As with the terminal 30g relay, the micropower module enables a defined deactivation of loads/consumers in the event of a fault, i.e. excessive closed-circuit current.

Deactivation only takes place with the vehicle at rest when a fault occurs in the communication area.

The following faults trigger deactivation:

- Excessive closed-circuit current in the event of a critical SoC
- Number of K-CAN wake-up procedures exceeded
- Undervoltage
- Vehicle does not go into sleep mode.

Integration in the K-CAN

The micro-power module is connected to the K-CAN.

The micro-power module detects 3 operating states, namely normal mode, sleep mode and service mode.

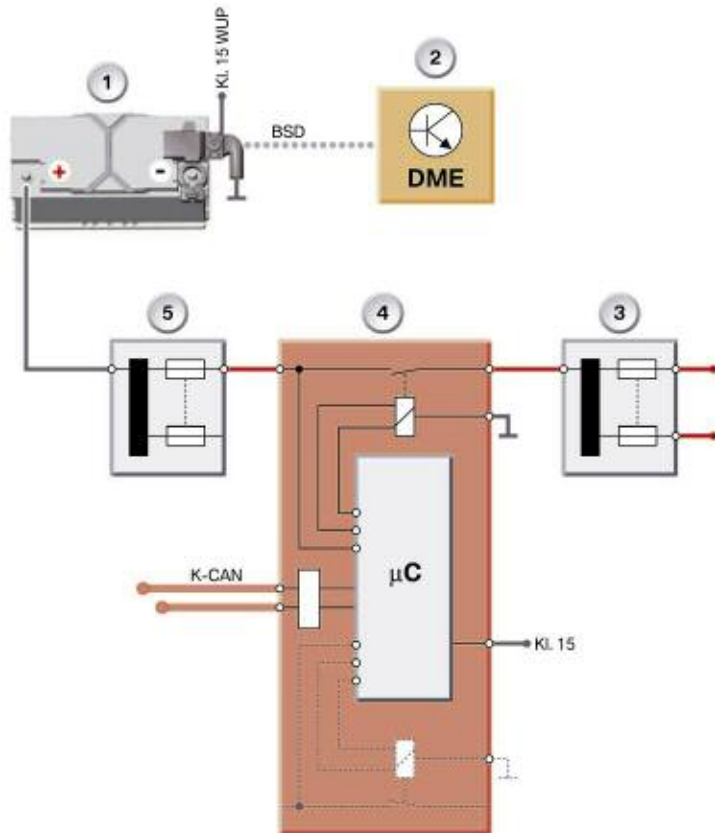

Index	Explanation
1	Battery
2	DME (Digital Motor Electronics)
3	Front power distribution box
4	Micro-power module
5	Rear power distribution box
BSD	Bit-serial data interface
K-CAN	Body CAN
KI.15	Terminal 15
KI.15 WUP	Terminal 15, wake-up

■ Normal mode

All functions of the micro-power module are available in normal mode.

The micro-power module switches OFF/ON the voltage supply to all the loads/consumers involved in communication.

These loads/consumers are:

- M-ASK (Multi-Audio System Controller)
- CCC (Car Communication Computer)
- CDC (Compact Disc Changer)
- DVD changer

The supply voltage is switched on and off by means of a bistable relay. The relay is set to "ON" when it leaves the factory. The switch-on condition has priority over the switch-off condition.

The switch-on conditions are:

- Creation for the first time of the supply voltage at the micro-power module "First Switch to Power"
- Locking/unlocking
- Terminal R "ON"
- Terminal R 15 "ON"
- Changes in status of door contacts or of trunk lid contact
- Bus activity

The switch-off conditions are:

- Excessive closed-circuit current in the event of a critical SoC
- Signal "Stationary loads/consumers OFF" by DME
- Undervoltage $< 9\text{ V}$ for a time period > 60 seconds
- Number of K-CAN wake-up procedures exceeded
- Bus activity after 60 minutes in spite of the vehicle having stopped, i.e. the vehicle cannot go into sleep mode after terminal R "OFF".

The relay disconnects the loads/consumers from the vehicle electrical system with a 5-minute delay. This delay allows the respective loads/consumers to sign off from the electrical system. The switch-off procedure is interrupted if a switch-on condition applies during this 5-minute period.

Special cases for switch-off conditions:

- The loads/consumers have already been disconnected from the vehicle electrical system
- The vehicle door is opened without the vehicle being started
- Bus activity

■ **Sleep mode**

The micro-power module goes into sleep mode approx. 1 second after the K-CAN has gone into sleep mode.

The current switching status of the relays is stored before the micro-power module goes into sleep mode.

The micro-power module is woken by the terminal 15 signal via the K-CAN or by activation of terminal 15.

On waking, the switching status of the relay last stored is reestablished.

Energy Management with Junction Box

Introduced with the E90 the Energy Management System with Junction Box uses an energy management function that is similar to that used in the E60 Micro Power Module System to ensure balanced power/energy distribution in the vehicle. The system was further developed for use in the E70 and it is currently part of the BN2020 in the F0x vehicles. This training material discusses all three systems with emphasis on F0x vehicles.

The energy management functions in vehicles with junction boxes are executed in the power management system of the DME (See chart on page 21 of this chapter). The IBS provides exact information regarding the condition of the battery such as actual voltage, current and internal temperature to the DME. This allows for greater flexibility in regulating loads and also provides additional diagnostic functions with regard to energy consumption.

There are two different systems, depending on the vehicle equipment specifications:

- BPM (Basic Power Management)
- APM (Advanced Power Management)

The BPM is identical to the basic energy management in other BMW vehicles. The BPM is installed without a IBS.

There are two different operating modes:

- Vehicle operation (terminal 15)
- Vehicle stationary (terminal R and terminal 30)

Basic Power Management

This variant features only idle speed increase and charging voltage specification.

Basic power management

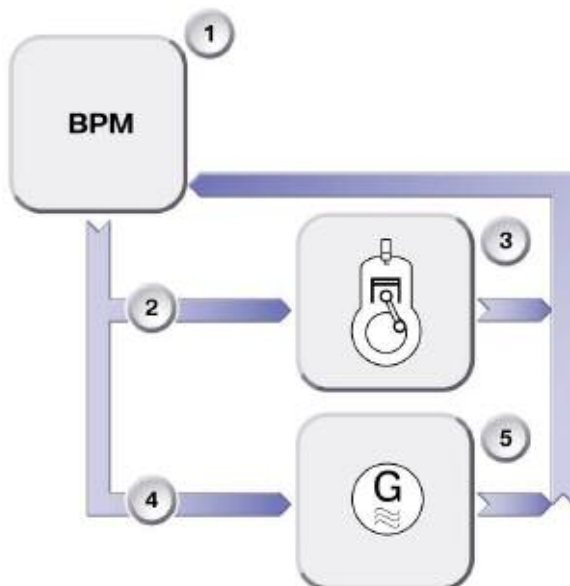

Index	Explanation
1	Basic power management
2	Idle speed increase
3	Combustion engine
4	Charging voltage specification
5	Alternator

■ BPM charging voltage specification

The BPM controls the voltage at the alternator depending on the temperature. The input variable here is the outside temperature. This input variable is used in the power management system to calculate the battery temperature.

Charging voltage increase

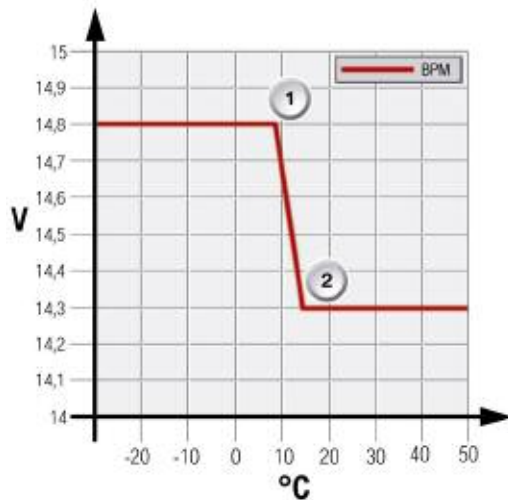

Index	Explanation
1	Normal charging voltage
2	Increased charging voltage

APM (Advanced Power Management)

The APM is used if an IBS is installed in the vehicle.

Advanced Power Management

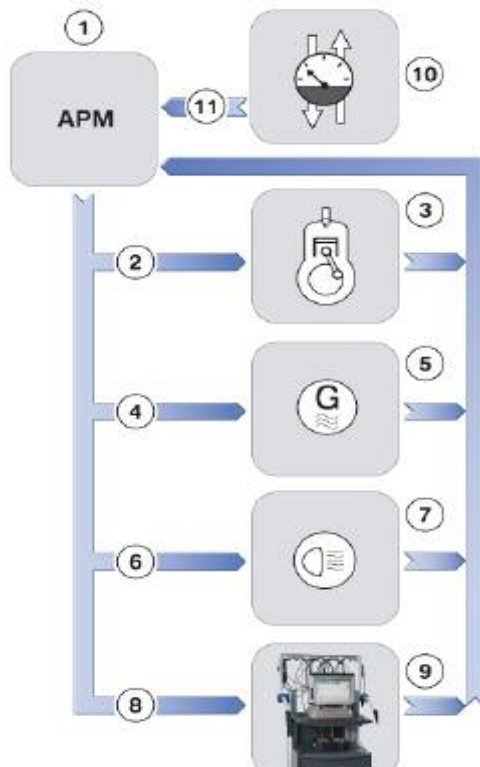

Index	Explanation
1	Advanced Power Management
2	Idle speed increase
3	Combustion engine
4	Charging voltage specification
5	Alternator
6	Consumption reduction
7	Load/consumer
8	Electrical system and battery diagnosis
9	BMW diagnosis system
10	Intelligent Battery Sensor
11	Battery data

Note: Most current US vehicles use the Advanced Power Management system.

The following functions are integrated in both management systems:

- Idle speed increase
- Charging voltage specification

In addition to the main functions of basic power management (idling speed and required battery charge voltage), APM also incorporates the following extended functions:

- Electric load reduction
- Electric load shut-down
- Vehicle systems diagnosis
- Battery diagnosis.

As is the case with energy management with the micro-power module, an IBS (intelligent battery sensor) is installed for APM.

APM charging voltage specification

With APM the outside temperature is not used to calculate the battery temperature. Here the battery temperature is measured directly with the IBS.

The power management uses this value as the input variable for calculating the battery temperature. With the aid of a calculation model, the specified charging voltage is set based on the battery temperature.

This information is sent via the BSD line to the alternator.

The required battery charge voltage is determined according to outside temperature and IGR function in most current FOx vehicles.

Index	Explanation
1	Model-based battery temperature of 8 °C
2	Model-based battery temperature of 19 °C
3	Emergency operation

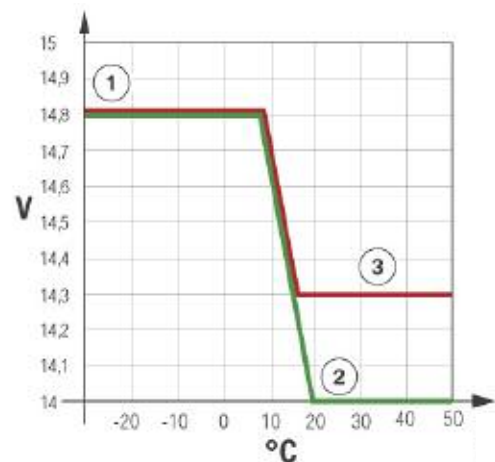

Voltage regulation on alternator on F01/F02

Effect of Outside Temperature

The required battery charge voltage function ensures electrochemically optimum battery charging by adjusting the battery charge voltage according to temperature. Since the current absorbed by a cold battery is lower, the voltage for charging must be higher than for a warm battery.

Conversely, if that higher voltage were constantly used to charge a warm battery, there would be a risk of gas formation. Therefore, the charge voltage is regulated on the alternator according to temperature. The current battery temperature is measured by the intelligent battery sensor (IBS) attached directly to the battery negative terminal and signalled to the engine management module (DME) via the LIN bus.

The power management uses this value as the input variable for calculating the battery temperature. With the aid of a calculation model, the specified charging voltage is set based on the battery temperature. This information is sent to the alternator via the bit-temperature of serial data interface (BSD).

Battery Regeneration

In order to ensure the availability of IGR Low, a certain level of unused capacity must always be retained in the battery. That is implemented by means of IGR High and IGR Medium. For the battery, that means that it is never fully charged. If a battery were not fully charged over a long period or were left fully discharged, sulphation could occur. Sulphation causes a battery to prematurely age, thereby reducing the usable proportion of its rated capacity. To prevent that occurring, the required battery charge voltage function performs a battery regeneration cycle in the course of which the battery is fully charged.

On vehicles with IGR function, regular battery regeneration phases are maintained in order to protect the battery against premature aging and loss of capacity due to cyclic discharge and sulphation. That involves the battery being fully charged using the maximum permissible charge voltage taking account of ambient conditions (temperature, charge level).

Emergency Operation

The APM makes use of emergency operation set to a constant 14.3 V. A fault code functions when there is a break in the LIN "Communication LIN" is entered in the fault interface. In this case, the alternator voltage is code memory of the engine management.

Electric Load Reduction

In order to reduce the power consumption in critical situations, not only can the idling speed be increased and the required charge voltage raised, the power of various non-essential electrical devices can be reduced or they can be switched off altogether. That prevents the battery being discharged.

The electrical devices (that consume power when the engine is running) are subdivided into two classes.

- **Class A**

A reduction of the power consumption or shut-down of these devices is only noticeable to the driver to a limited degree or after a delay. Individual Class A devices are only switched off or have their power consumption reduced under the following 2 conditions:

- Battery charge status in critical range
- High load on alternator.

- **Class B**

A reduction of the power consumption or shut-down of these functions is immediately noticeable to the driver. Individual Class B devices are only switched off or have their power consumption reduced under the following condition:

- Battery charge status in critical range.

Class A Electrical Devices

The following measures are taken for Class A devices under the conditions specified above:

Sequence	Function	Operation	Control unit
1	Rear window defogger	Clocking	IHKA
2	Seat heating, rear Electric auxiliary heater, rear	Stage 2 75%	SM FAH SM BFH JB FKA
3	Seat heating, front Seat heating, rear	Stage 2 50%	SM FA SM BF JB SM FAH SM BFH JB
4	Electric auxiliary heater, rear	50%	FKA
5	Seat heating, front Seat heating, rear	50% Stage 1	SMFA SMBF JB SM FAH SM BFH JB
6	Electric auxiliary heater, rear Steering wheel heating	25% 50%	FKA SZL
7	Electric auxiliary heater, rear Mirror heating Washer-jet heating	OFF OFF OFF	FKA FRM/JB JB
8	Steering wheel heating	OFF	SZL
9	Seat heating, front Seat heating, rear	OFF OFF	SMFA SMBF JB SM FAH SM BFH JB

Sequence	Function	Operation	Control unit
10	Rear window defogger	OFF	IHKA
11	Top-HiFi system or BMW individual high end audio system	Maximum 30 A power consumption after engine started	Top HiFi High End Audio

All measures are implemented in the specified order.

Class B Electrical Devices

The following measures are taken for Class B devices under the conditions specified above:

Sequence	Function	Operation	Control unit
1	Top-HiFi system or BMW individual high end audio system Heater fan, front and rear	Maximum 30 A power consumption in general 75%	Top HiFi High End Audio IHKA FKA HKA
2	Heater fan, front and rear	50	IHKA FKA HKA
3	Heater fan, front and rear	25%	IHKA FKA HKA

All measures are implemented in the specified order.

Once the battery charge level is outside the critical range, the functions are fully available again.

Note: While shut-down of individual devices or reduction of their power consumption is active, the displays remain active (LEDs remain on).

Note: If devices have their power consumption reduced or are switched off, a fault memory entry is registered and the history memory records the duration, odometer reading, and the function concerned.

■ Electric load reduction

In vehicles with APM, in addition to increasing the idle speed and the charging voltage specification, it is also possible to deactivate various loads/consumers to reduce power consumption.

Load/consumer deactivation is performed under the following two conditions:

- State of battery charge in critical range
- Alternator fully utilized

■ Energy Flow

During vehicle operation, the mechanical energy of the engine is converted by the alternator into electrical energy and made available to the electric loads. The electric loads receive their power supply mainly via terminal 30g and via terminal 30g_f.

Certain electric loads are also still supplied directly by terminal 30 or by terminal R. For example, the anti-theft alarm system (DWA) must still remain active when the vehicle is parked.

Current flow during vehicle operation

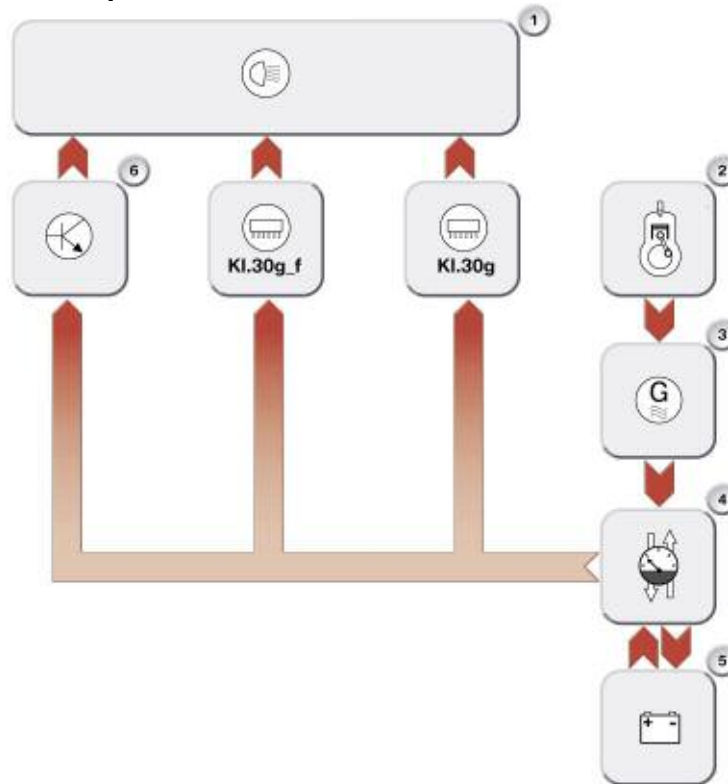

Index	Explanation	Index	Explanation
1	Electric loads	5	Vehicle battery
2	Drive motor	6	Control units
3	Alternator	Kl.30g	Terminal 30, switched
4	Intelligent Battery Sensor	Kl.30g_f	Terminal 30 switched, fault dependent

■ Information Flow

The calculations necessary for controlling the energy balance take place in the power management. The idle speed and charging voltage are regulated while the engine is running. The power intake of electric loads with relatively high power consumption is reduced or the loads are switched off as required.

Certain electric loads can be switched off when the engine is stationary. This takes place either time-controlled via the CAS and the terminal 30g relay or in response to electrical faults via the engine control, junction box and the terminal 30g_f relay.

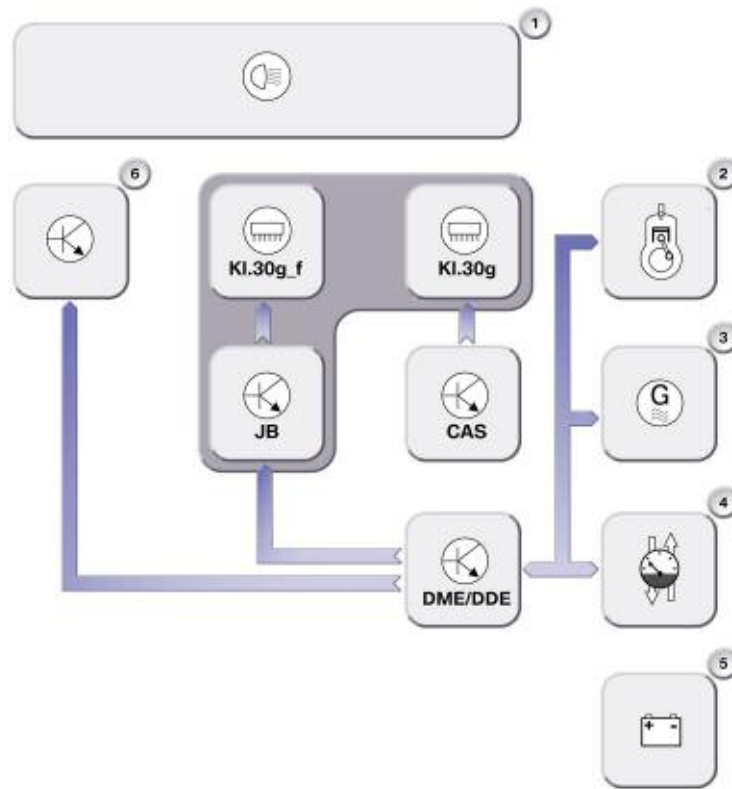

Index	Explanation	Index	Explanation
1	Electrical loads	4	Intelligent Battery Sensor
2	Engine	5	Vehicle battery
3	Alternator	6	Control units

Vehicle in Stationary Mode (terminal R and terminal 30)

■ Electric Loads in Stationary Mode

Certain electric loads may be active even when the closed-circuit current monitoring facility of the power management is already in operation. This is necessary for various reasons:

- Legally required electric loads, e.g. side lights, hazard warning system
- Convenience for the customer, e.g. radio function, telephone

These electric loads must be excluded from the closed-circuit monitoring system in order to avoid misinterpretation in the power management. For this purpose, these electric loads must log in with the power management.

In turn, the power management recognizes the activity and accepts the higher power consumption when the systems are deactivated, the corresponding control units log off from the power management.

■ Stationary Load Log-off

The power management in the engine control can send a request to switch off the active electric loads in stationary mode depending on the battery charge status and the start capability limit. As a result, the stationary loads must deactivate their functions irrespective of the terminal status and must reach their closed-circuit current within 5 minutes. Legally required electric loads are excluded from this function.

■ Terminal 30g and Terminal 30g_f

The system is equipped with various relays for switching off the power supply to most control units. There are two terminal 30g relays in the front and rear power distribution boxes. The terminal 30g_f relay in the rear power distribution box is required for the following optional equipment:

- Multi-audio system controller
- Car communication computer
- Comfort Access
- Instrument cluster
- Telephone US/telephone preparation US

The terminal 30g relay switches off the connected electric loads after 30 minutes. The after-running time is extended to 60 minutes if a telephone or auxiliary heating system is installed in the vehicle. The terminal 30g relay is activated by the CAS.

The terminal 30g_f relay is activated by the junction box control unit and switches off the connected electric loads if a fault occurs. The terminal 30g_f relay is a bistable relay. Each switching status is retained even when no power is applied.

The relays are controlled by following control units:

- Terminal 30g_f - activation by the junction box control unit

The calculation necessary for activating the terminal 30g_f relay takes place in two control units. The following activities are monitored in the junction box control unit:

- Invalid wake-up procedures within the bus systems
- Sleep blockers (control units that constantly keep the bus systems active)

The battery values are constantly read and evaluated in the engine control unit. The relay is also switched off when the starting capability limit of the vehicle battery is reached.

- Terminal 30g - activation by the CAS

Description	Explanation
KL15	Ignition (position 2)
KL R	Accessory (position 1)
KL 30	B+ Constant
KL 30g	B+, time dependent
KL 30 g_f	B+, fault dependent

Note: Switching terminal 30g_f results in a reset of the instrument cluster. This means the time must be reset again.

Note: For more information regarding terminals and relays, refer to the Terminal Control section of this training material.

30g/30g_f relays wiring diagram

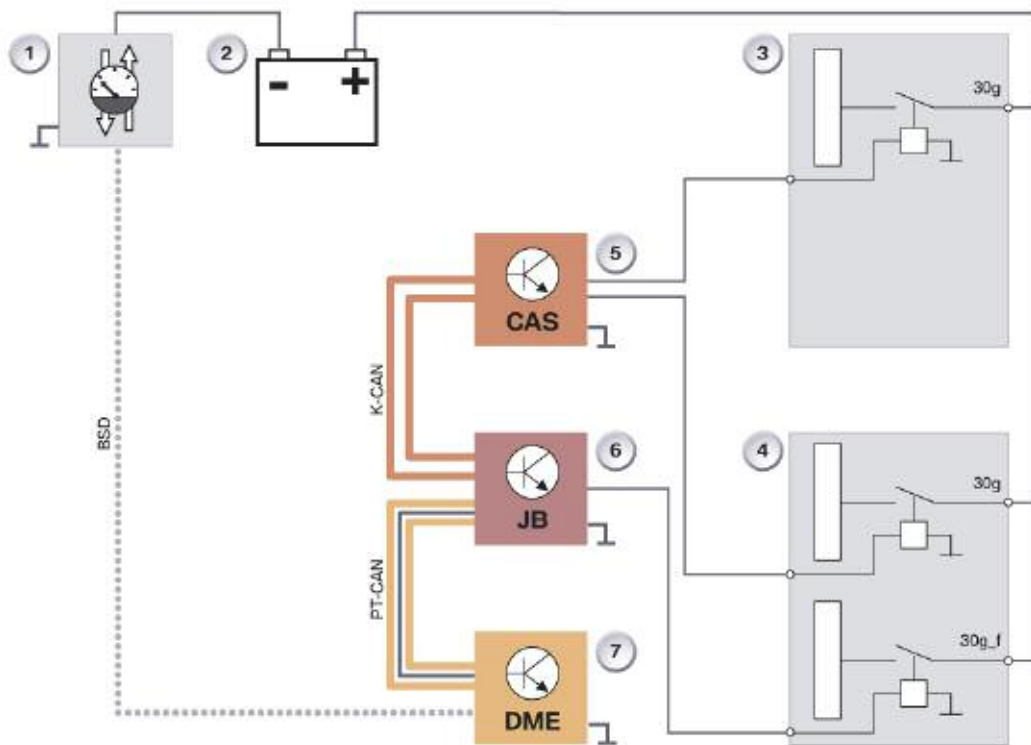

Index	Explanation	Definition/Function
1	IBS	Monitors voltage, current and temperature
2	Vehicle battery	Supplies power via the power distribution boxes to the individual loads
3	Front power distribution box with terminal 30g relay	Equipped with one relay for load shutdown (KL30g)
4	Rear power distribution box with KL30g and KL30g_f relays	Equipped with two relays for load shutdown (KL30g and KL30g_f)
5	CAS 3	Responsible for controlling KL30g relay in the power distribution boxes
6	Junction Box Control unit	Responsible for controlling the KL30g_f relay
7	Digital Motor Electronics	Responsible for evaluating the measured data of the IBS and requests activation by the junction box control unit as required. When the charge status of the battery is low, at "terminal R OFF", the engine management additionally sends a request to switch off terminal 30g to the CAS.

General Measures (E70)

The terminals "load shut-down" and the terminal "interior lighting" are switched off as a general measure when the vehicle is in stationary mode. This occurs only when the vehicle is not locked and secured. These loads are shut down immediately when the vehicle is locked and secured.

This measure affects the following electric loads:

Electric Loads	Terminal
Interior lighting (front and rear)	Load shut-down after 8 minutes (immediately if locked)
Footwell lighting (front and rear)	Load shut-down after 8 minutes (immediately if locked)
Reading light (front and rear)	Load shut-down after 8 minutes (immediately if locked)
Vanity mirror light	Load shut-down after 8 minutes (immediately if locked)
Terminal R	Load shut-down 8 minutes after opening door (immediately if locked, only on vehicles with Comfort Access)
Terminal R	Load shut-down after 2 minutes at poor battery charge status (immediately if locked, only on vehicles with Comfort Access)
Light (switch position 2 - low beam)	Load shut-down after "terminal R OFF" and door open

■ Continuous Positive

As before, various electric loads are connected directly to terminal 30. The PDC control unit is connected to terminal 15.

Note: For more information regarding terminals and relays, refer to the Terminal Control section of this training material.

System Components

Components

The components of the energy management system are:

- Engine
- Alternator
- Vehicle battery
- Intelligent battery sensor
- Junction box module
- Engine management (power management)
- Loads

The most important components of the energy management system are described in the following.

Intelligent Battery Sensor (IBS)

The intelligent battery sensor has a similar range of functions to the intelligent battery sensor on previous models. A new feature is data transmission between the IBS and the engine management module via LIN bus and the wake-up function of the IBS.



Index	Explanation
1	Battery negative terminal
2	IBS
3	Battery negative lead

The intelligent battery sensor (IBS) is a mechatronic component for monitoring the battery condition. The description “intelligent” indicates that the IBS has an integral microprocessor. That microprocessor performs the computation and assessment of time-critical measured variables.

The power supply for the IBS is provided by a separate lead from the power distribution box on the battery. The data from the IBS is passed to the higher-level control units (DME) via the LIN bus. If necessary, the IBS can wake up the Junction box module via a separate lead.

IBS in vehicle network

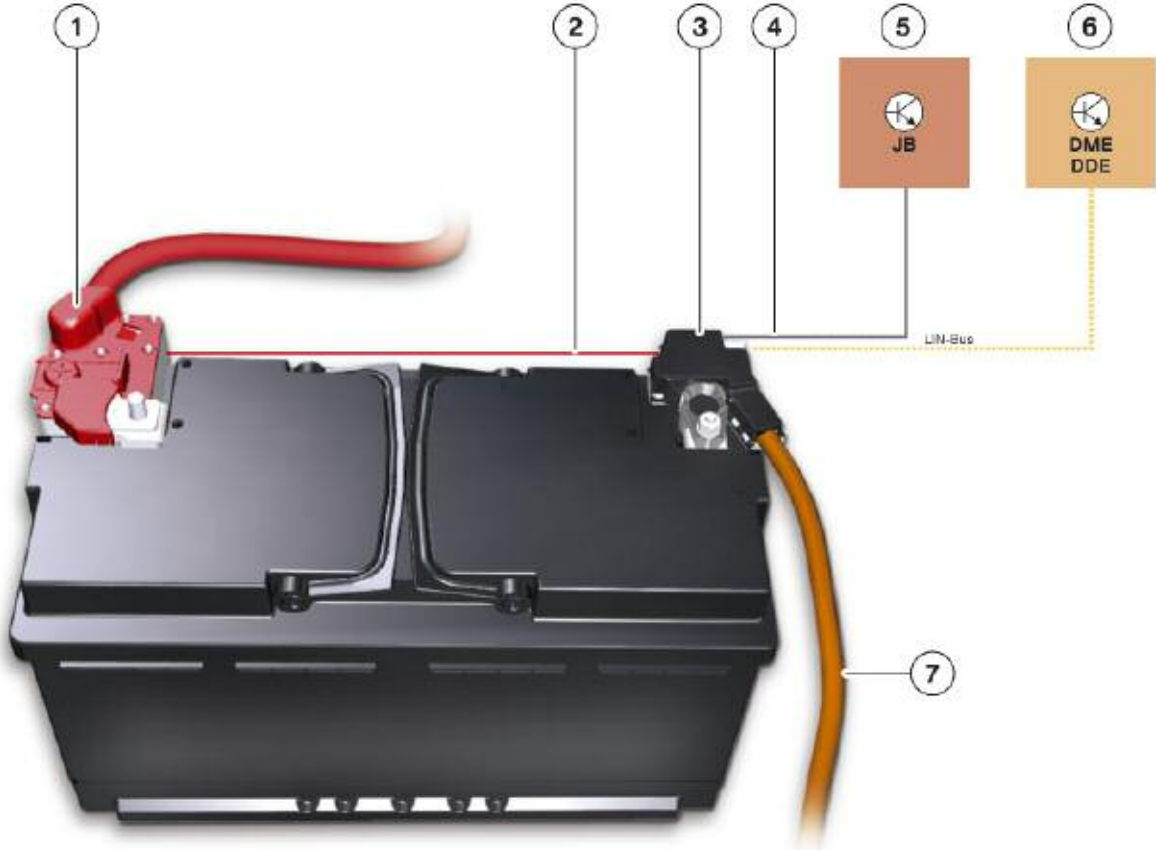

Index	Explanation	Index	Explanation
1	Battery positive lead	5	Junction box module
2	Power supply for IBS	6	ECM (DME)
3	IBS	7	Battery negative lead
4	Wake-up line	LIN	Local Interconnect Network bus

The following physical battery variables are registered by the IBS:

- Current
- Voltage
- Terminal temperature.

Among other things, the following main functions are integrated in the IBS:

- Continuous measurement of the battery current, voltage and temperature under all vehicle operating conditions.
- Calculation of the battery indicators as the basis for the charge and health status of the battery. The battery indicators are charge and discharge current, voltage and temperature of the vehicle battery. Alongside calculation of the battery indicators, preliminary computation of the battery charge level (“state of charge”, SOC) is also carried out.
- Balancing of the charge/discharge current of the battery.
- Continuous monitoring of the battery charge status and making available the corresponding data in the event of insufficient battery power.
- Calculation of the current progression when starting the engine to determine the battery health status.
- Closed-circuit current monitoring of the vehicle.
- Self-diagnosis

Wake-up Function

When the vehicle is in idle mode, the IBS continuously records the data relevant to the battery indicators. The IBS is programmed to wake up every 14 seconds in order to update the measured data by taking new readings. The time required to take the readings is approximately 50 milliseconds. The measured data is stored on the IBS in the memory for recording the closed-circuit current.

The wake-up function applies only when the vehicle is in idle mode. If the IBS detects a wake-up trigger, the Junction box module is woken up by a PWM signal. The IBS is directly connected to the Junction box module via a separate lead.

The pulse duty factor indicates the reason for the wake-up:

Pulse duty factor	Reason for wake-up
20%	Starting capacity, limit 1
40%	Starting capacity, limit 2
60%	Raised closed-circuit current

A wake-up due to raised closed-circuit current can take place up to three times.

Depending on the vehicle status and reason for the wake-up, the Junction box module performs one of the following actions:

- Wakes up the vehicle so that the DME can send shut-down commands to electrical devices that are operating while the vehicle is in parked mode
- Resets Terminal 30F (without waking up the vehicle)
- Switches off Terminal 30F (without waking up the vehicle).

A fault memory entry is registered in each case.

Commissioning

The IBS is fully functional as soon as it has been fitted to the battery terminal (screwed to the grounding point and connected to the signal leads), i.e. it can immediately detect the basic variables, current, voltage and temperature.

However, the variables derived from those readings for the purposes of power management, i.e. battery condition, starting capacity, etc., must first be recalculated and, therefore, there is a time lag before they are available.

When the engine is restarted, the DME reads off the closed-circuit current progression. If it diverges from the defined closed-circuit current progression, a fault is registered in the DME fault memory.

In the period between “Engine OFF” and when the DME main relay is switched off, the IBS is informed by the DME as to the maximum charge that can be drawn from the battery on the basis of ensuring that the engine can be reliably restarted. After the DME main relay is switched off, the IBS continually checks the battery charge level (SOC) and the closed-circuit current.

Note: For more information regarding energy management components refer to the Power Supply section of this training material.

Junction Box Module

The Junction box module (JBE) is responsible for switching the Terminal 30F relay and for storing information (history data and fault memory entries) related to energy management. As part of vehicle diagnostics, these data can be used to evaluate faults and to analyse the vehicle battery.

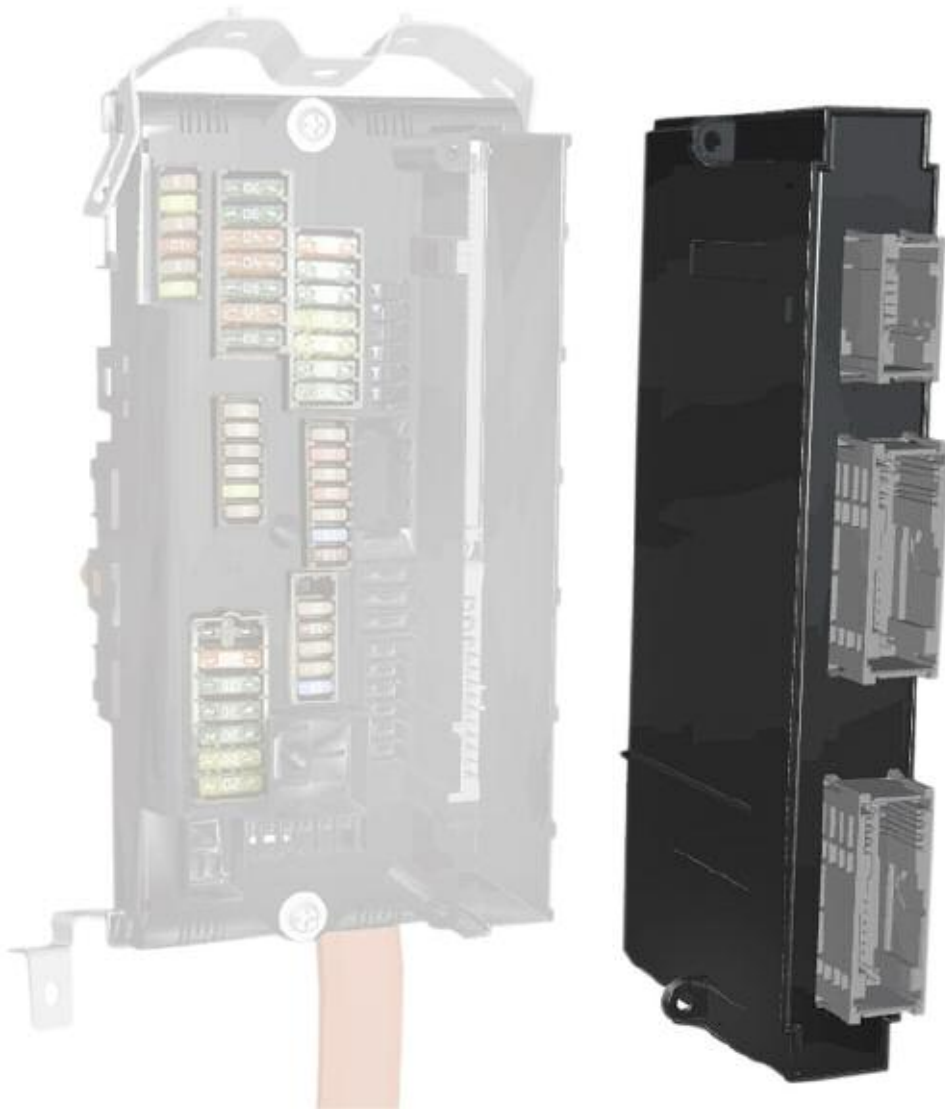

Engine Management (Power Management)

The (power management) software for controlling the energy balance is located in the engine management. On the basis of that control algorithm, various electrical devices in the vehicle's electrical system are switched off by the CAS control unit via the Terminal 30B relay or by the Central Gateway Module and engine management module via the Terminal 30F relay. The power management is additionally responsible for evaluating and storing the IBS data.

Terminal Control

The terminals are switched on and off by turning the key in the ignition lock (if equipped).



Index	Explanation
1	Terminal 0
2	Terminal R
3	Terminal 15
4	Terminal 50 (engine start)

On vehicles without an ignition lock, the terminals are switched on and off by pressing the Start-Stop button. The identification transmitter (remote control) must be inserted and locked in its holder. The vehicle then automatically receives the terminal status terminal R ON.

Terminal control on vehicles with Start-Stop button

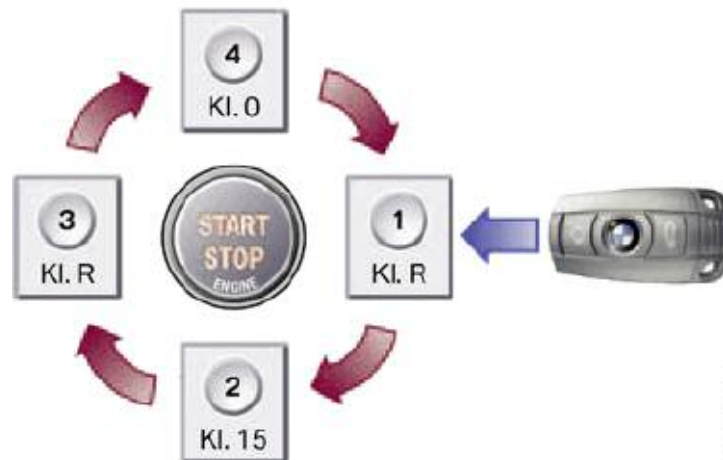

The terminals can now be switched with the START-STOP button in the following order:

- Terminal R (1)
- Terminal 15 (2)
- Terminal R (3)
- Terminal 0 (4)

This sequence is only possible when the brake pedal is not pressed on automatic transmission vehicles and the clutch pedal on manual transmission vehicles. As soon as the brake or clutch pedal is depressed, the engine will start the next time the START-STOP button is pressed.

On vehicles equipped with comfort access, the identification transmitter needs only to be located in the vehicle interior and not necessarily inserted in the holder.

The identification transmitter is detected via the interior aerial. Provided the vehicle was shut down correctly, the terminal switching procedure start with the status terminal 0. The terminals can now be selected one after the other by pressing the START-STOP button.

Terminal 30g and terminal 30g_f

Depending on the vehicle and system, there may be more terminals in the junction box for power supply:

- Terminal 30g and
- Terminal 30g_f

These terminals are switched by relays in the junction box.

The terminal 30g relay is always installed.

The terminal 30g_f relay is installed only when one of the following options is ordered:

- M-audio system controller (MASK)
- Car communication computer (CCC)

Time-dependent Shutdown (terminal 30g)

The terminal 30g relay switches off the connected electrical loads after 30 minutes.

The afterrunning time is extended to 60 minutes if a telephone is installed in the vehicle.

The terminal 30g relay is activated by the car access system. In the most current vehicles control units such as the CID (central information display), DSC (dynamic stability control), CON (controller) are supplied with voltage via this terminal.

Fault-dependent Shutdown (terminal 30g_f)

The terminal 30g_f relay is controlled by the junction box control unit and switches off the connected electric loads (MASK or CCC) if a fault occurs. The terminal 30g_f relay is a bistable relay. Each switching status is retained even when no power is applied.

The terminal 30g_f relay is switched on and off under the following conditions.

Terminal 30g_f ON at:

- Unlock vehicle or
- Terminal R or
- Change in contact status (rear lid and doors)

Terminal 30g_f OFF at:

- Receiving the "Signal OFF" message. Terminal 30g_f relay is switched off after 5 minutes.
- Bus activity for 60 minutes with no switch on condition applicable.
- Vehicle is woken 30 times with no switch on condition applicable.

The terminal 30g_f relay is a bistable relay and is always switched on under normal conditions. It switches off the connected electric loads only in the case of fault. Once the terminal 30g_f relay has been switched off, one of the switch-on conditions is necessary in order to switch it on again.

New Terminal Designation

As of the introduction of the F01/F02 (Boardnet 2020 platform) new designations for some of the terminals were implemented. A distinction is also made between logical terminals and power supply terminals.

The logical terminals are:

- Terminal R
- Terminal 15
- Terminal 50

Note: All Boardnet 2020 F0x vehicles are based on the F01 Terminal Control.

The logical terminals do not serve as power supply terminals; instead, they represent a status. They are activated/deactivated by pressing the START-STOP button. Their status is signalled to the control units by means of a bus message.

The power supply terminals are:

- Terminal 30
- Terminal 15N
- Terminal 30B
- Terminal 30F

Terminal	Description
Terminal 15	Terminal 15N
Terminal R	Radio setting
Terminal 30	Continuous positive
Terminal 30g	Continuous positive, time dependent
Terminal 30g_f	Continuous positive, fault dependent

The table below details the previous and new terminal designations.

Previous	New
Terminal 15	Terminal 15N
Terminal 30g	Terminal 30B
Terminal 30g_f	Terminal 30F

Terminal 15N

Terminal 15N is used to supply power to control units and components that are only intended to be active when the vehicle is being driven, e.g. PDC.

The letter “N” stands for “Nachlauf”, meaning “overrun”. The power supply Terminal 15N is switched on and off by means of the logical Terminal 15. The overrun time after Terminal 15N is switched off is 5 seconds. That time is required so that the control units have enough time to save their data. While Terminal 15N is active, Terminal 30B and Terminal 30F are also active.

Terminal 30B

Terminal 30B supplies power to control units and electrical components that are required when the driver is present.

The letter B stands for “Basic mode”.

Terminal 30B is activated by:

- Pressing the buttons on the radio remote control
- Unlocking/locking/double-locking the vehicle
- Pressing the START-STOP button
- Change of door switch status, change of trunk switch status, change of side-window position
- Bus message

Regular deactivation by:

- Vehicle double-locked and tailgate closed (one minute overrun)
- Vehicle not double-locked or tailgate open (30 minutes overrun)

Other possible deactivation triggers:

- Upper starting capacity limit reached (one minute overrun)
- “Powerdown”: diagnosis command for purposes of measuring closed-circuit (10 seconds overrun)
- Transport mode (one minute overrun)

While Terminal 30B is active, Terminal 30F is also active.

Terminal 30F

Terminal 30F supplies power to control units and electrical devices that are also required when the driver is not present but which can be switched off in the event of a fault.

Use: all control units that are not supplied by Terminal 15N or Terminal 30B, are not responsible for vehicle access and do not have to meet a legal requirement for permanent operation.

The letter “F” stands for “Fault”.

Terminal 30F is activated by:

- Pressing the buttons on the radio remote control.
- Unlocking/locking/double-locking the vehicle.
- Pressing the START-STOP button.
- Change of door switch status, change of tailgate switch status, change of side-window position.
- Bus message.

In the event of a fault (closed-circuit current too high, bus wake-up, sleep-mode inhibitor, start capacity limit reached) Terminal 30F is reset for 10 seconds.

Terminal 30F is not reset or switched off if at least one of the following conditions is met:

- Terminal 30B active.
- Parking lights switched on.
- Side lights switched on.
- Hazard warning lights switched on.
- If an extended overrun time for Terminals 30B and 30F is demanded by a service message from any of a number of control units. Example: when the engine is warm, it can be necessary for the electric fan to run on for up to 11 minutes after the vehicle is parked and locked. In order for the electric fan to be operated, the engine management module must be supplied with power. Since the overrun time in that case is only three minutes (that is currently the short overrun time for Terminal 30B, not one minute), the DME requests the appropriate extension by way of a bus message when the engine is switched off.
- “Sticking relay” detected.

Terminal 30F is switched off if Terminal 30B is off and at least one of the following conditions is met:

- Starting capacity limit reached.
- Another 10 bus wake-ups have occurred after Terminal 30F reset.
- Unexplained bus activity after Terminal 30F reset.
- Violation of closed-circuit current limit detected after Terminal 30F reset.

F0x Terminal Control

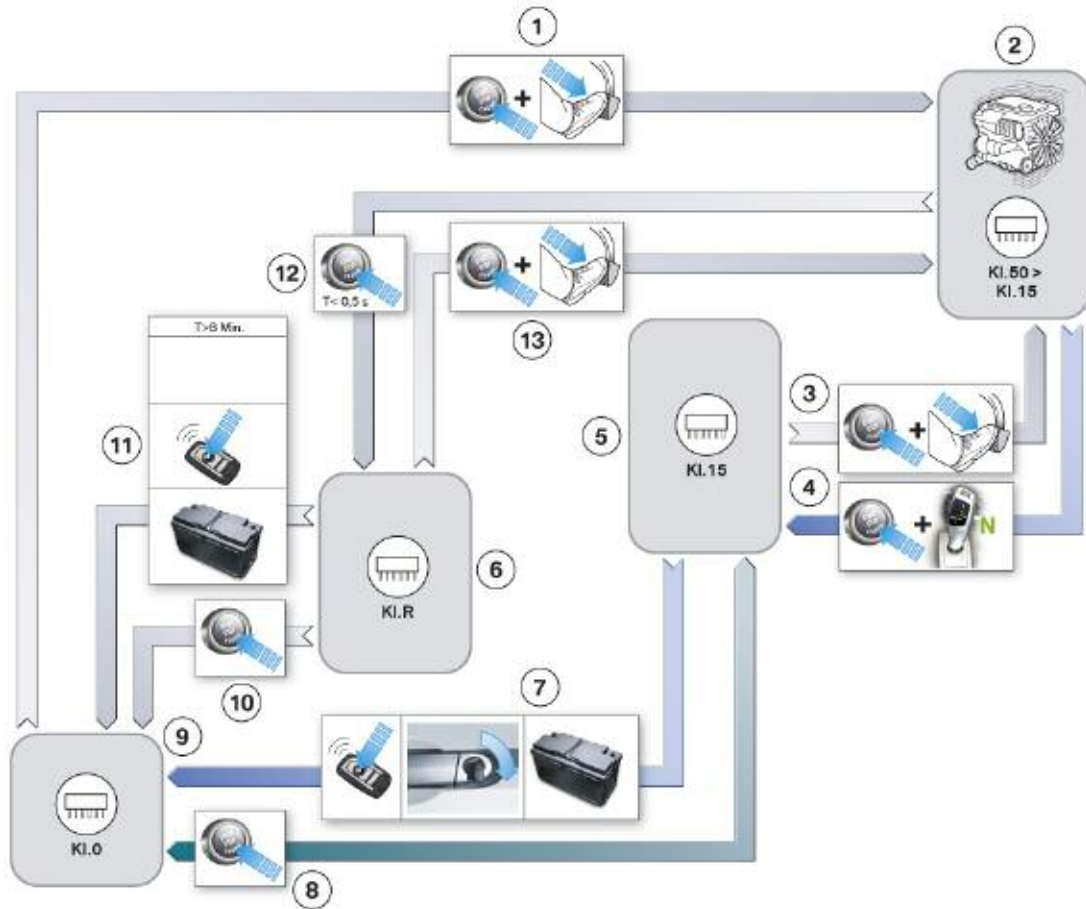

Index	Explanation	Index	Explanation
1	START-STOP button pressed and brake pedal operated → Terminal 50 is activated and engine starts	8	Pressing the START-STOP button toggles terminal status between Terminal 15 and Terminal 0.
2	Engine running (Terminal 50 > Terminal 15)	9	Terminal 0
3	START-STOP button pressed and brake pedal operated → Engine starts.	10	Pressing the START-STOP button changes the terminal status from Terminal R to Terminal 0.
4	If selector lever is in position "N" and the engine is stopped by pressing the START-STOP button, Terminal 15 remains on for 15 minutes.	11	Change from Terminal R to Terminal 0 if more than 8 minutes elapsed or vehicle is locked or starting capacity limit reached.
5	Terminal 15	12	START-STOP button briefly pressed → Engine stops. Terminal R.
6	Terminal R	13	START-STOP button pressed and brake pedal operated → Engine starts.
7	Terminal 15 OFF when vehicle is locked or starting capacity limit reached.		

■ Terminal Relays

The F0x vehicles have various relays for switching off the power supply to most control units.

Location	Relay	Connection	Controlled by:
Front fuse box	KL 15N	Soldered	CAS
Front fuse box	KL 30B	Plugged in	CAS
Front fuse box	KL30F (bistable)	Soldered	ZGM/DME
Rear fuse box	KL 15N	Soldered	CAS
Rear fuse box	KL 30B	Plugged in	CAS
Rear fuse box	KL30F (bistable)	Soldered	ZGM/DME

The Junction box module controls the bistable relays for Terminal 30F but receives the request from the central gateway module (ZGM) or IBS.

- ZGM: If sleep mode inhibited or on occurrence of unauthorized wake-up. ZGM monitors the vehicle status and registers inhibited sleep mode or unauthorized wake-up after Terminal 30B is switched off.
- IBS: If closed-circuit current limit violated or starting capacity limit reached.

The computation for activating the Terminal 30F relay takes place on two control units. The ZGM monitors the following activities:

- Invalid wake-up procedures within the bus systems.
- Sleep blockers (control units that constantly keep the bus systems active).

The ECM (DME) continuously reads and assesses the battery data. The relay is also switched off when the starting capability limit of the vehicle battery is reached.

The Terminal 30F relay is a bistable relay and is always in the ON state under normal conditions. It switches off the connected electric loads only in the case of fault. Once the Terminal 30F relay has been switched off, one of the switch-on conditions must be met before it can be switched on again.

Note: More information on this topic can be found in the Reference Information on the CAS.

General Measures (F0x)

The terminals "load shut-down" and the terminal "interior lighting" are switched off as a general measure when the vehicle is in stationary mode. This occurs only when the vehicle is not locked and secured. These loads are shut down immediately when the vehicle is locked and secured. This measure affects the following electric loads:

Electric loads	Terminal
Interior lighting (front and rear)	Load shut-down after 8 minutes (immediately if double locked)
Footwell lighting (front and rear)	Load shut-down after 8 minutes (immediately if double locked)
Reading light (front and rear)	Load shut-down after 8 minutes (immediately if double locked)
Vanity mirror light	Load shut-down after 8 minutes (immediately if double locked)

Note: For more information regarding Terminal Control and the Car Access System (CAS) refer to the EWS/CAS section of this training material.

Power Supply Schematics

E65 Power Supply

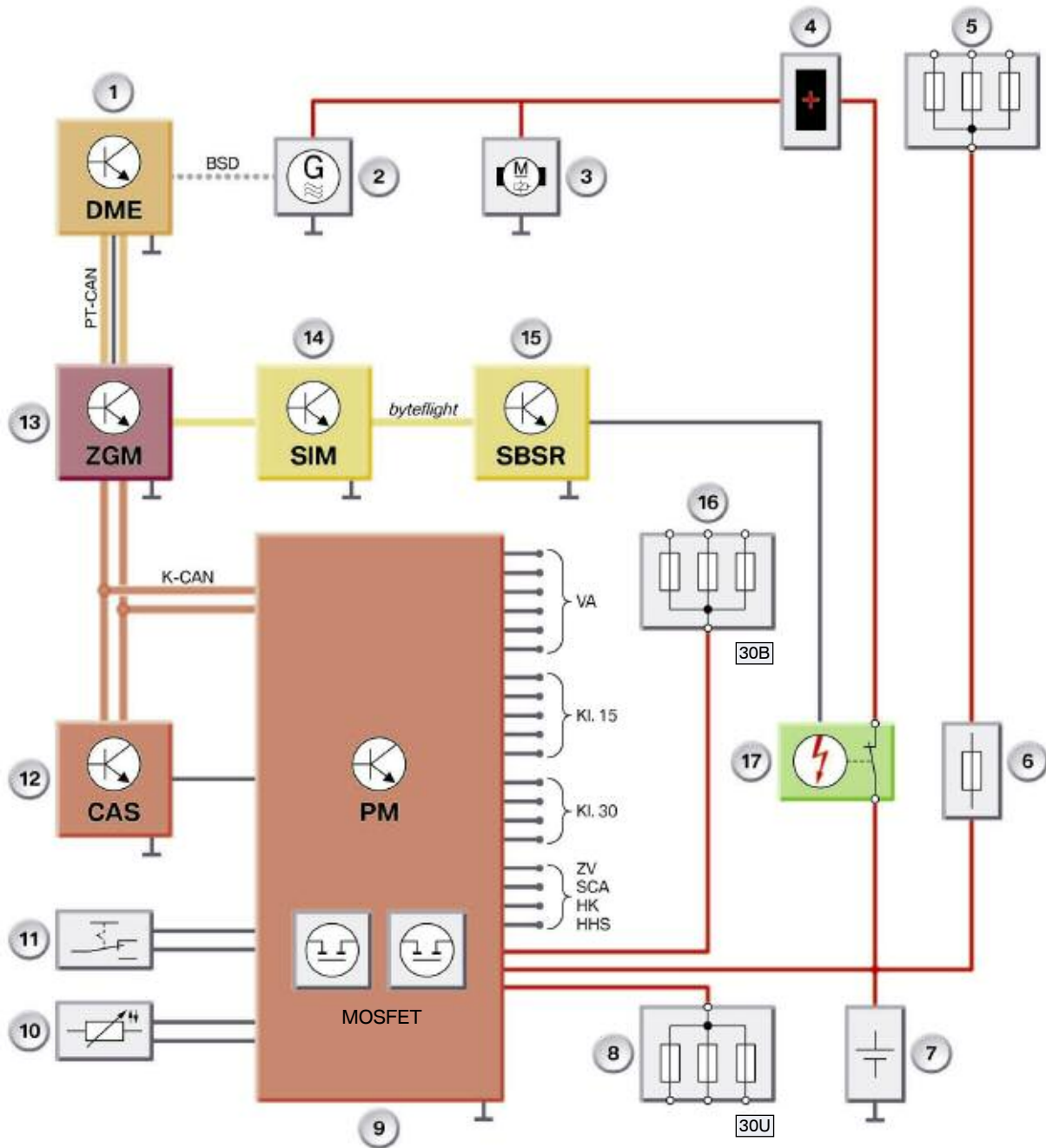

Index	Explanation
1	DME (Digital Motor Electronics)
2	Alternator
3	Starter
4	Jump start terminal point
5	Fuse carrier, engine compartment
6	Main fuse
7	Battery
8	Fuse carrier, luggage compartment
9	Power module
10	Temperature sensor
11	Battery switch
12	CAS (Car Access System)
13	ZGM (Central Gateway Module)
14	SIM
15	SBSR
16	Fuse carrier , glove box
17	Battery Safety Terminal (BST)

E60 Power Supply

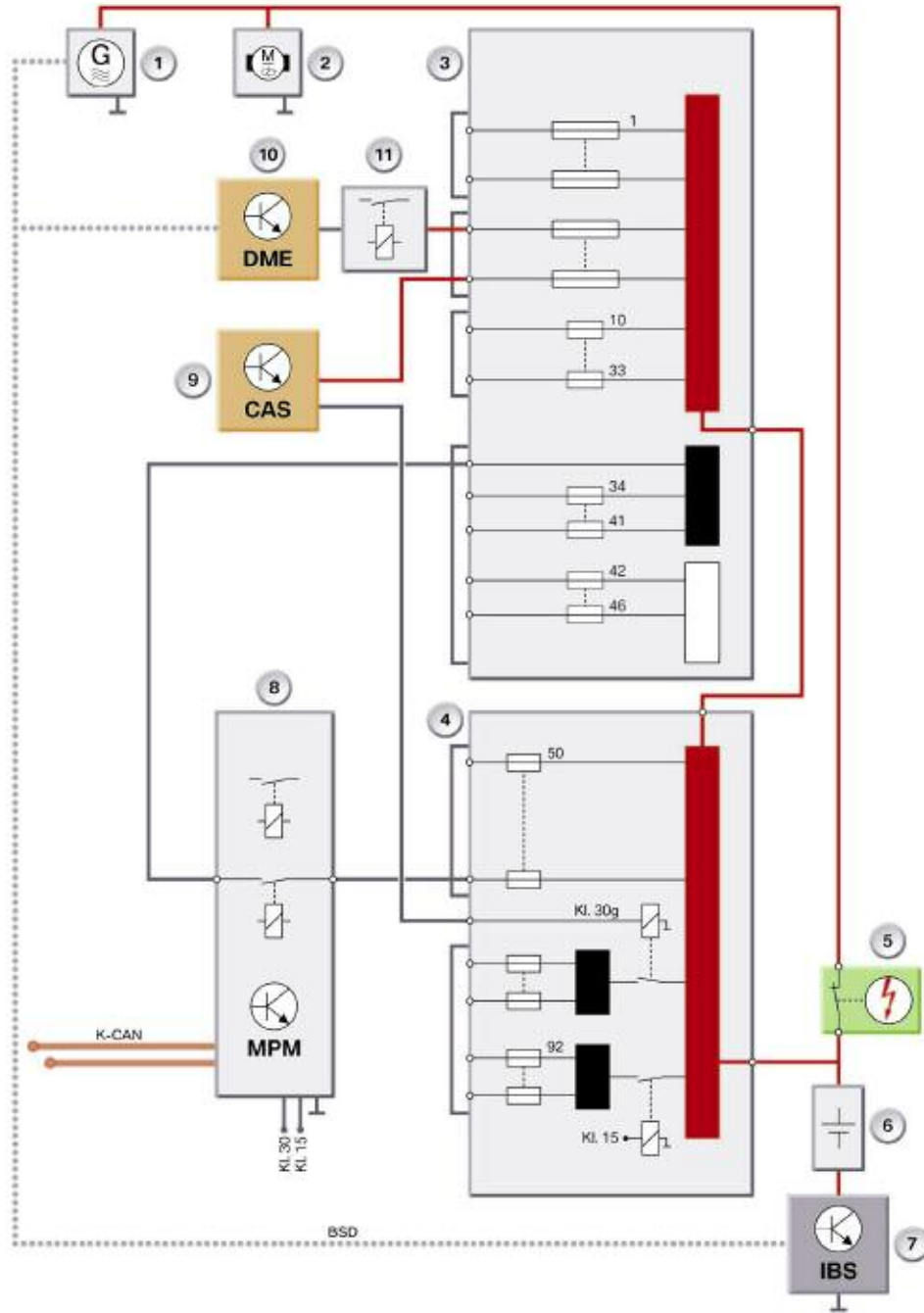

Index	Explanation	Index	Explanation
1	Alternator	7	Intelligent Battery Sensor
2	Starter	8	Micro-power module
3	Front power distribution box	9	CAS (Car Access System)
4	Rear power distribution box	10	DME (Digital Motor Electronics)
5	Battery Safety Terminal	11	DME main relay
6	Battery		

E90 Power Supply

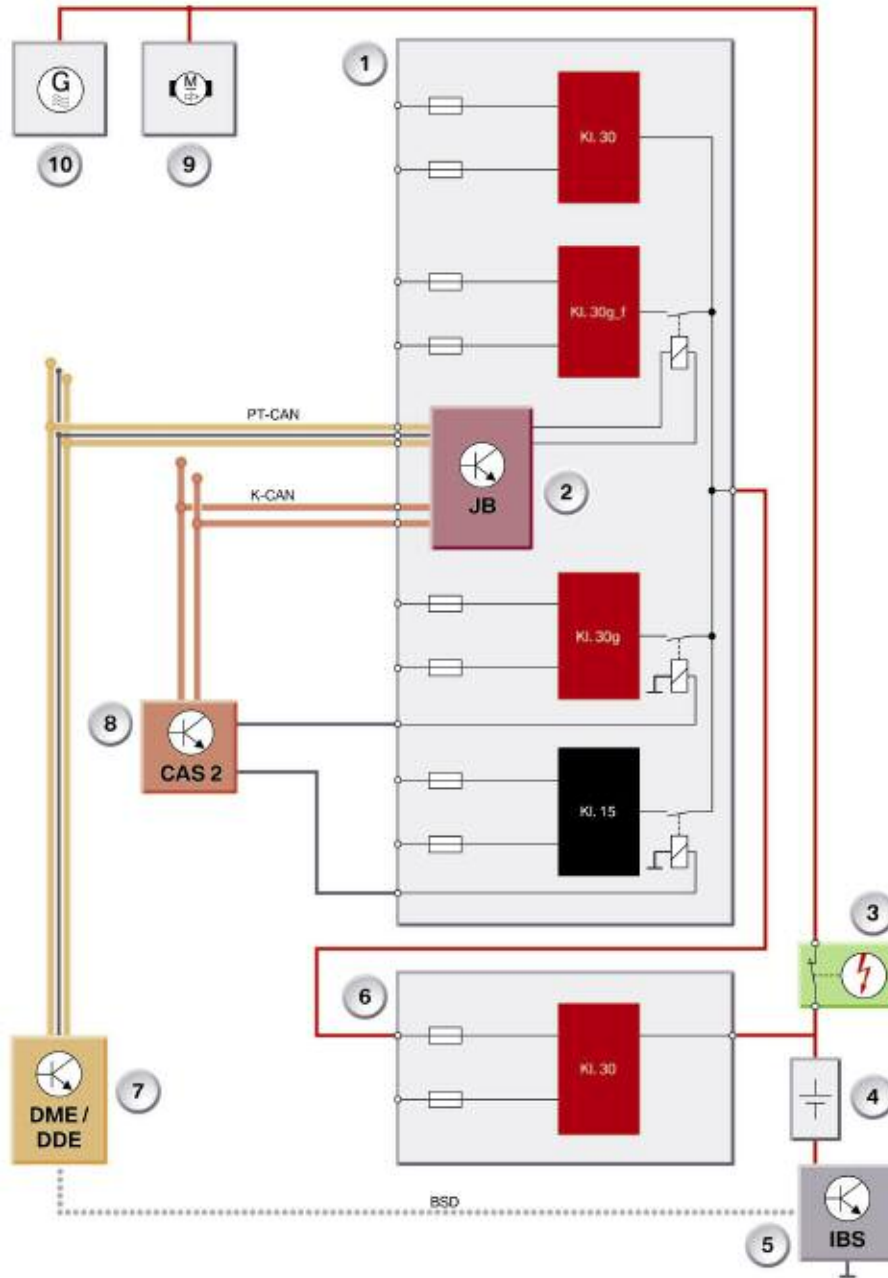

Index	Explanation	Index	Explanation
1	Front power distribution box	8	CAS (Car Access System)
2	Junction Box	9	Starter
3	Battery Safety Terminal	10	Alternator
4	Battery	KI.30	Continuos positive
5	Intelligent Battery Sensor	KI.30g_f	Switch positive, fault dependent
6	Rear power distribution box	KI.30g	Switch positive, time dependent
7	DME (Digital Motor Electronics)	KI.15	Ignition

E70 Power Supply

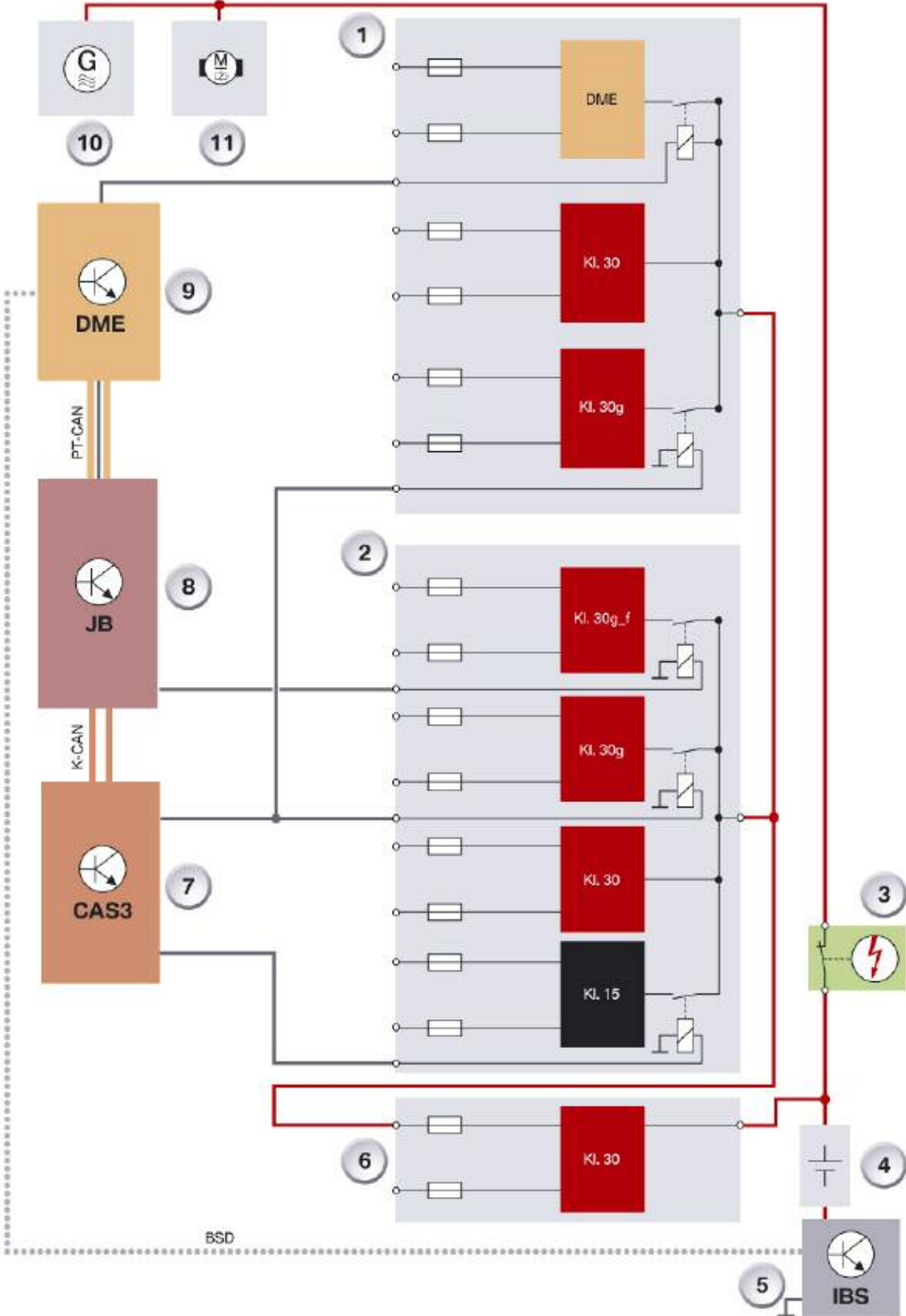

Index	Explanation
1	Front distribution box, behind glove compartment
2	Rear distribution box, right hand side of luggage compartment
3	Safety battery terminal
4	Vehicle battery
5	Intelligent battery sensor (IBS)
6	Distribution box, on battery
7	Car Access System 3 (CAS 3)
8	Junction box control unit (JBE)
9	Digital Motor Electronic (DME)
10	Alternator
11	Starter
KL30	Continuous B+ (battery power)
KL30g_f	Switched positive (fault dependent)
KL30g	Switched positive, time dependent
KL15	Ignition ON
DME	DME main relay
BSD	Bit-serial data interface
K-CAN	Body CAN
PT-CAN	Powertrain CAN

F01/F02 System Circuit Diagram

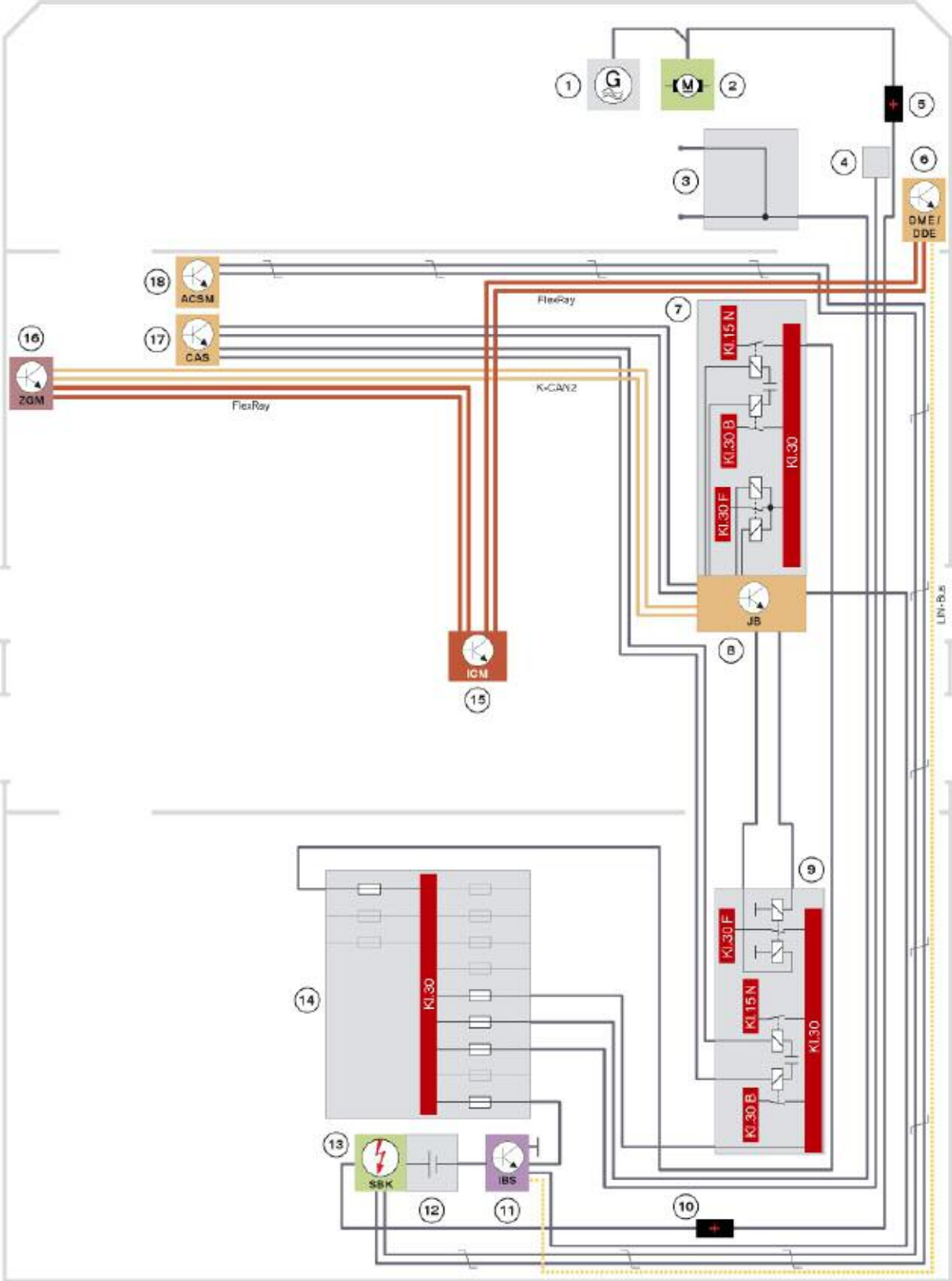

Index	Explanation
1	Alternator
2	Starter
3	Power distribution box in engine compartment
4	Electronics box
5	Positive battery terminal
6	DME Digital Motor Electronics; DDE Digital Diesel Electronics
7	Front fuse carrier, behind the glove compartment
8	Junction box electronics
9	Rear fuse carrier, on the right-hand side of the luggage compartment
10	Transfer point on the luggage compartment floor
11	Intelligent battery sensor IBS
12	Vehicle battery
13	SBK safety battery terminal
14	Distribution box on the battery
15	ICM Integrated Chassis Management
16	ZGM central gateway module
17	Car Access System CAS
18	ACSM crash safety module
KL30	Continuous positive 30
KL30B	Terminal 30 basic operation
KL30F	Terminal 30 fault switched
KL 15N	Terminal 15 overrun
LIN-bus	Local Interconnect Network bus
K-CAN 2	Body controller area network 2

NOTES

PAGE